

JUMO AQUIS 500 AS

Indicator/controller for standard signals

Brief description

The instrument has 2 analog inputs and 1 binary input. The first analog input is suitable for connecting standard or standardized signals (0 to 10 V or 0/4 to 20 mA), which can be prepared by any transmitter or sensor (such as a 2-wire transmitter). Pt100, Pt1000 or NTC/PTC resistance thermometers (up to 4 k ohms) can be connected to the second analog input. The power supply for a 2-wire transmitter is integrated in the instrument.

Input signals can be shown as numbers or as a bar graph on the graphic display. Parameters are displayed in plain text for easily comprehensible and secure operation.

With two optional relay switching contacts, it is possible to implement both simple switching or alarm functions and demanding control tasks with P, PI, PD and PID action. If required, the instrument can also be provided with two freely configurable and scalable analog outputs (0 to 10 V or 0/4 to 20 mA).

The instrument is suitable, for example, for displaying, measuring, and controlling:

- free chlorine, hydrogen peroxide, peracetic acid, chlorine dioxide and ozone in combination with sensors as per data sheet 202630
- the pH value or redox potential with 2-wire transmitters as per data sheet 202701
- (hydrostatic) liquid levels with 2-wire transmitters (level and pressure measuring instruments) as per data sheet 402090 or data sheet 404390
- flow rate in combination with relevant transmitters.
- two temperature measuring points.
- most sensors and transmitters that output standard signals (0 to 10 V or 0/4 to 20 mA).



Type 202568

Block diagram

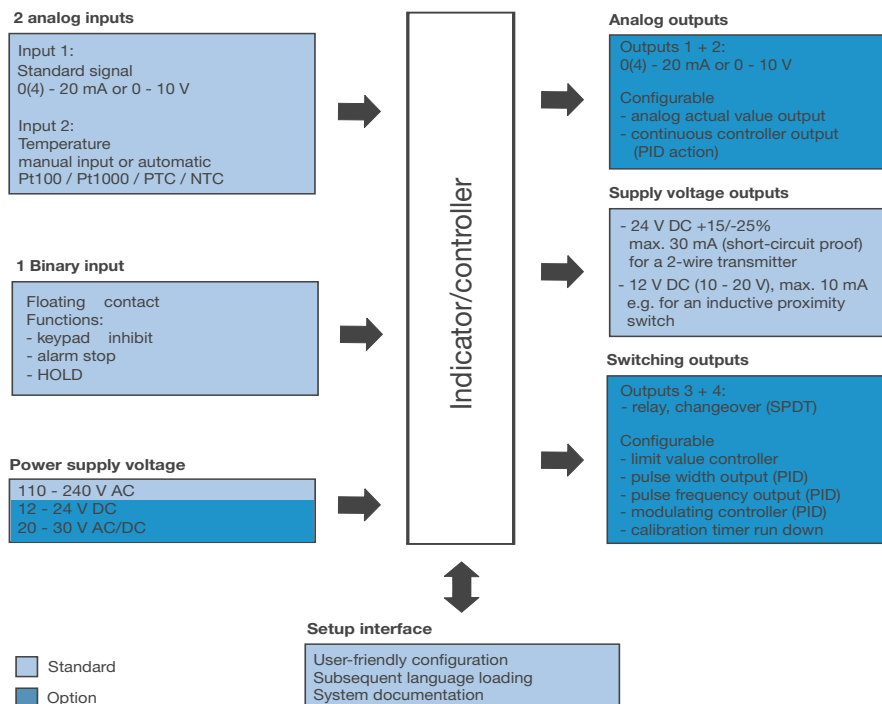

Key features

- Display: mg/l, pH, mV, μS/cm, etc. Special visualizations are also possible with the setup program
- large, backlit LC graphic display
- a choice of display visualizations: large numbers, bar graph or trend display
- integrated calibration routines: 1-point and 2-point
- Calibration logbook
- IP67 enclosure protection for surface mounting
IP65 enclosure protection for switch cabinet mounting
- selectable languages: German, English, French; additional languages can be loaded later through the setup program
- the setup program¹ allows: user-friendly configuration, system documentation, subsequent loading of additional languages

¹ Option

Approvals/Approval marks (see Technical data)



Functional description

The instrument is designed for on-site use. A robust housing protects the electronics and electrical connections against aggressive environmental conditions (IP67). As an alternative, the instrument can also be installed in a panel; the front then has IP65 enclosure protection. Easily installed screw connectors are used for electrical connection. A ventilation screw with a PTFE membrane prevents condensation buildup.

Displays and controls

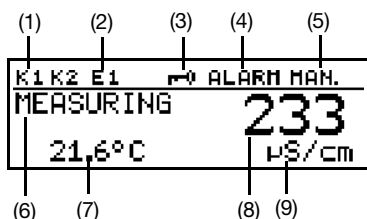

- (1) switching output 1 or 2 is active
- (2) binary input 1 is triggered
- (3) keypad inhibited
- (4) alarm has been activated
- (5) instrument is in manual mode
- (6) instrument status
- (7) temperature of measured medium
- (8) main measurement
- (9) unit of main measurement

The user can specify what is to appear in positions (7) and (8) of the display:

- no display
- corrected or uncorrected measurement
- temperature
- output level 1 or 2
- setpoint 1 or 2

Operation

To make programming and operation easy, all parameters are clearly assigned to levels and displayed in plain text. Operation is protected by a code word. Operation can be adapted on an individual basis because parameters can be generally enabled or assigned to the protected area.

A setup program for the PC is available as a more convenient configuration option, rather than using the instrument keypad.

Display modes

Three display modes are available:

Large numbers

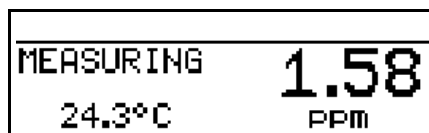

Here the measurements are displayed in numbers, as usual.

Trend display

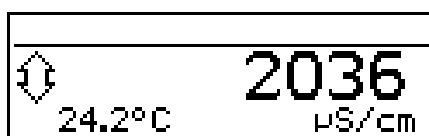

Here the numerical value is supplemented by a symbol to indicate the direction and speed of change for the measurement. This can be very useful when the controller is being optimized, for example.



from left to right:

fast, medium and slow rise, steady, slow, medium and fast fall.

Bar graph

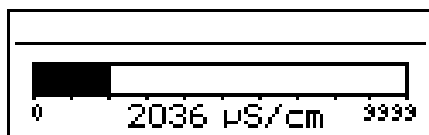

In this display mode, it only takes a glance to ascertain the range for the current measurement.

Any scale can be used for the bar graph.

Function modes

Linear scaling

This mode is selected when the input signal is to be displayed linearly.

One of the following units is used for display or control:

- μS/cm
- mS/cm
- %
- mV
- pH
- ppm
- customized (5 characters)

Sensors can be connected to the instrument for the following measurement variables, for example:

- free chlorine, chlorine dioxide, ozone, hydrogen peroxide and peracetic acid as per data sheet 202630
- redox potential as per data sheet 202701
- liquid level measurements
- flow rate measurements, etc.

The instrument has three calibration options available in this function mode:

- zero point
- end value
- zero point and end value

This allows optimum adaptation of the instrument to the sensor.

Conductivity

This mode is intended for sensors that make uncorrected standard signals available. μS/cm or mS/cm are the units used for display or control.

Different calibration routines can be activated:

- Calibrating the cell constant. Because of manufacturing constraints, the cell constant of a conductivity measuring cell may differ slightly from its nominal value (the value printed on it). Wear or the accumulation of deposits during operation can also cause the cell constant to change. This changes the output signal from the measuring cell. With this instrument, the user has the opportunity to compensate for deviations in the nominal value of the cell constant by **manual input** (80 to 120 % range) or **automatic calibration** of the relative cell constant K_{rel} .

- Calibrating the temperature coefficient α . The conductivity of virtually all solutions is temperature-dependent.

To ensure correct measurement therefore, both the temperature and the temperature coefficient α [%/K] of the measurement solution must be known. The temperature can either be measured automatically with a Pt100 or Pt1000 temperature probe or the user must set the temperature by hand.

The temperature coefficient can be determined automatically by the instrument or entered manually in the 0 to 5.5 %/K range.

Concentration

In this mode, the concentration of a liquid can be determined from its uncorrected conductivity.

% or "customized" are the units used for display or control.

Concentration measurement:

Caustic soda

NaOH 0 to 15 % by weight

NaOH 25 to 50 % by weight

Nitric acid

HNO₃ 0 to 25 % by weight

HNO₃ 36 to 82 % by weight

Sulphuric acid

H₂SO₄ 0 to 28 % by weight

H₂SO₄ 36 to 85 % by weight

H₂SO₄ 92 to 99 % by weight

Hydrochloric acid

HCl 0 to 18 % by weight

HCl 22 to 44 % by weight

The cell constant can be calibrated.

pH or redox

Connection option for transmitters that emit an uncalibrated pH or redox standard signal, such as JUMO data sheet 202701 2-wire transmitters.

The AQUIS 500 AS provides the required supply voltage for this type of 2-wire transmitter.

pH: a pH calibration (zero point or zero point and slope) can be performed, as well as the option of temperature compensation. "pH" display and control variable.

Redox: Both relative and absolute calibration are possible (zero point or as a percentage, using reference values). "mV" or "%" display and control variables.

Customized with table

Non-linear correlations between the input and output variable can be processed in this mode. Typical applications include measuring the level of liquid in horizontal, cylindrical containers or simply measuring the concentration.

The input values are processed in a table (max. 20 value pairs). Values can only be entered in the table using the optional setup program.

The units used for display or control are:

- $\mu\text{S}/\text{cm}$
- mS/cm
- customized (5 characters)
- Use the offset parameter to adjust the display.

Analog outputs

As many as two analog outputs are available (programmable 0(4) to 20 mA or 0(2) to 10 V).

The main input variable is assigned to **analog output 1**.

The (Pt100/Pt1000/NTC) temperature input is assigned to **analog output 2**.

Depending on the configuration, the two outputs output the actual value signal of the assigned measurement variable or the continuous controller signal of the main value. With the analog actual value output, the start and end values of the measurement range are freely adjustable.

The behavior of the outputs in the event of overrange or underrange measurements, alarms and calibration, is freely programmable.

Further functions of the JUMO AQUIS 500 AS

Simulation function:

The analog actual value outputs and relay outputs can be set as required in "manual" mode. This function is used, for example, for the "dry-run" commissioning of a system, for troubleshooting or during servicing.

Min/max value memory

This memory records the minimum and maximum input quantities that occur. This information can be used, for example, to assess whether the design of the connected sensor is suitable for the values that actually occur.

Binary input

The following functions can be accessed through the binary input:

- Key inhibit activation
When this function is activated, operation is no longer possible via the keypad.
- "HOLD" mode activation
When this function is activated, the outputs (analog and relay) adopt the states previously defined.
- Alarm suppression (controller alarm only)
With this function, it is possible to temporarily deactivate alarm generation via the relevantly configured relay.

The predefined function is activated by shorting the relevant terminals (with the floating contacts of a relay, for example).

Control functions

The instrument provides both simple switching functions (limit function, alarm window and pulse contact) as well as more significant control functions.

P, PI, PD and PID structures can be freely programmed as control functions.

Simple switching functions can be assigned to main and secondary inputs.

The more significant control functions can only be assigned to the main input.

Relay outputs

Two relay changeover contacts are available for the main measurement variable and/or the temperature.

The following functions can be programmed:

- Switching direction (min/max)

- Limit controller (switch-on/switch-off delay, hysteresis)
- Pulse width output¹ (main value only; see control functions)
- Pulse frequency output¹ (main value only; see control functions)
- Modulating function¹ (main value only; see control functions)
- Pulse controls
With this function, the output briefly switches on when the switching point is reached and then switches off again
- Alarm
- Sensor/range error
- Behavior in the event of an alarm, underrange or overrange measurement, calibration and "HOLD"

Contact functions

Max. limit function

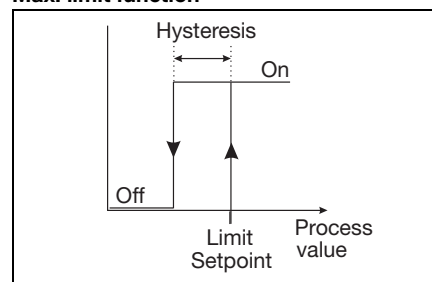

Min. limit function

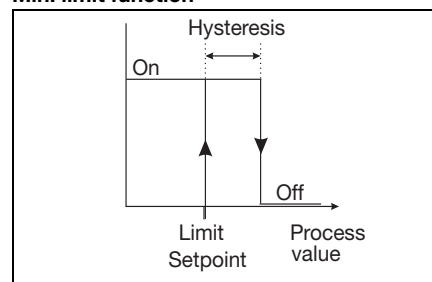

Alarm window 1

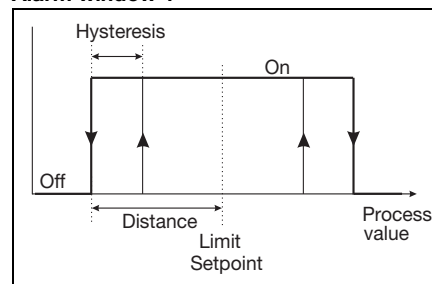

¹ Can only be assigned to the main variable.

Alarm window 2

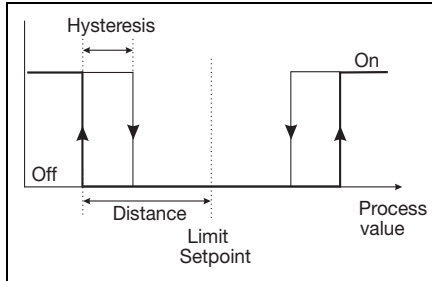

Pulse contact

Triggering condition longer than pulse duration

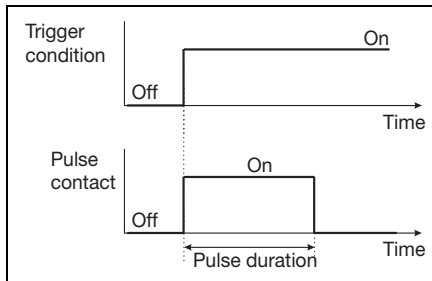

Pulse contact

Triggering condition shorter than pulse duration

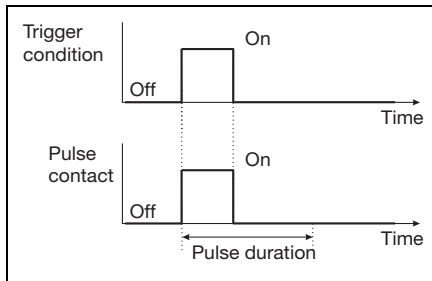

Pulse width controller

(output active with $x > w$ and P control structure)

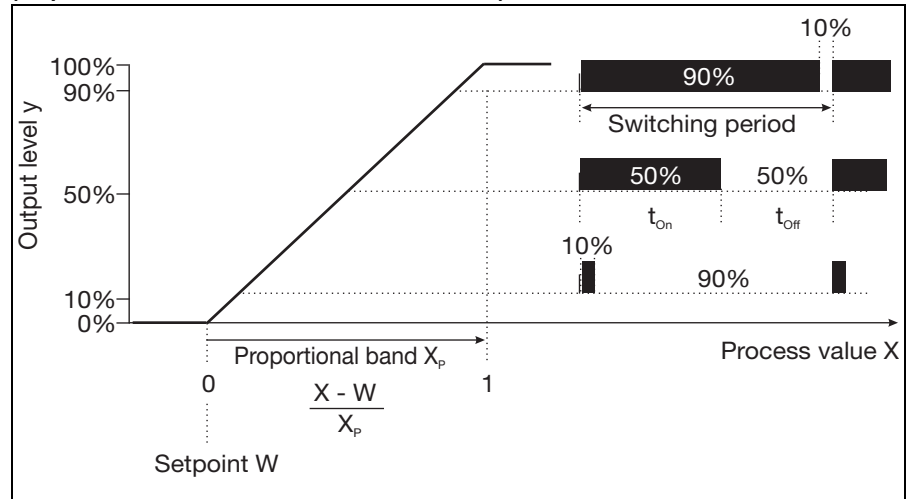

If actual value x exceeds setpoint w , the P controller will control in proportion to the control deviation. When the proportional band is exceeded, the controller operates with an output level of 100 % (100 % clock ratio).

Pulse frequency controller

(output active with $x > w$ and P control structure)

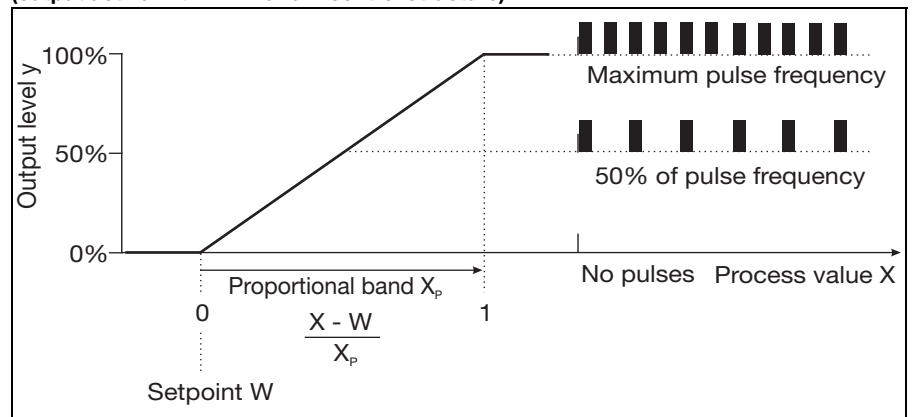

If actual value x exceeds setpoint w , the P controller will control in proportion to the control deviation. When the proportional band is exceeded, the controller operates with an output level of 100 % (maximum switching frequency).

Technical data

Analog inputs

Main input	Display range	Accuracy	Temperature error
0(4) to 20 mA 0 to 10 V	0.000 to 9.999 00.00 to 99.99 000.0 to 999.9 0000 to 9999	≤ 0.6 % of range	0.2%/10 °C
Secondary input	Measuring range	Accuracy	Temperature error
Temperature Pt100 (automatic detection)	-50 to +250 °C ^a	±0,5 K (up to 100 °C) ±0,8 K (as of 100 °C)	0.05%/10 °C
Temperature Pt1000 (automatic detection)		±0,5 K (up to 100 °C) ±1,0 K (as of 100 °C)	
Temperature NTC/PTC	max. 4 kΩ Input via table with 20 value pairs through setup program	≤ 0.3 % ^b	0.05%/10 °C

^a Selectable in °F

^b Dependent on interpolation points

Temperature compensation

	Compensation	Range ^a
in pH function mode	linear	-10 to +150 °C
in conductivity function mode	linear, 0 to 5.5 %/°C	-10 to +100 °C
	natural water (ISO 7888)	0 to 36

Reference temperature is adjustable from 15 to 30 °C; preset to 25 °C (default)

^a Note the sensor operating temperature range!

Measuring circuit monitoring

Inputs	Overrange/underrange	Short circuit	Sensor break
Main variable	yes	dependent on signal type	dependent on signal type
Temperature	yes	yes	yes

Binary input

Activation	by floating contact
Function	key inhibit HOLD alarm stop

Controller

Controller type	limit controller, pulse length controller, pulse frequency controller, modulating controller, continuous controller
Controller structure	P/PI/PD/PID
A/D converter	dynamic resolution up to 14 bits
Sampling time	500 ms

Analog outputs (max. 2)

Output type	Signal range	Accuracy	Temperature error	Permissible load resistance
Current signal	0(4) to 20 mA	≤ 0.25 %	0.08 %/10 °C	≤ 500 Ω
Voltage signal	0 to 10 V	≤ 0.25 %	0.08 %/10 °C	≥ 500 Ω

The analog outputs behave in accordance with NAMUR recommendation NE43.
They are electrically isolated, AC 30 V/DC 50 V.

Switching outputs (max. two (SPDT) changeovers)

Rated load	3 A/250 VAC (resistive load)
------------	------------------------------

Contact life	> 2 × 10 ⁵ operations at rated load
--------------	--

Supply voltage for sensors

Supply voltage for 2-wire transmitter	DC 24 V; -15/+20 % max. 30 mA
Voltage supply for inductive proximity switch ^a	DC 12 V; 10 to 20 V max. 10 mA

^a e.g. type EI1808 NPOSS

Setup interface

Interface for configuring the instrument with the available setup program option (for instrument configuration only).

Electrical data

Power supply voltage	AC 110 to 240; -15/+10 %; 48 to 63 Hz AC/DC 20 to 30 V; 48 to 63 Hz DC 12 to 24 V; +/-15 % (permissible only for connection to SELV/PELV circuits)
Power consumption	approx. 14 VA
Electrical safety	DIN EN 61 010, Part 1 overvoltage category III ^a , pollution degree 2
Data backup	EEPROM
Electrical connection	pluggable screw terminals conductor cross-section max. 2.5 mm ² (supply voltage, relay outputs, sensor inputs) conductor cross-section max. 1.5 mm ² (analog outputs, supply voltage for sensors)

^a Not valid for SELV/PELV of power supply variant DC 12 - 24 V

Display

Graphic LC display	120 × 32 pixels
Background lighting	Programmable: <ul style="list-style-type: none"> • off • on for 60 seconds during operation

Housing

Material	ABS
Cable entry	Cable glands, max. 3 × M16 and 2 × M12
Feature	ventilation to prevent condensation
Ambient temperature range (the specified accuracy is adhered to in this range)	-10 to +50 °C
Operating temperature range (instrument operational)	-15 to +65 °C
Storage temperature range	-30 to +70 °C
Climatic rating	rel. humidity ≤ 90 % annual mean, no condensation (based on EN 60721 3-3 3K3)
Enclosure protection to EN 60529	surface-mounted housing: IP67 panel mounting: at front IP65, at rear IP20
Vibration resistant	to EN 60068-2-6
Weight	surface-mounted housing: approx. 900 g panel mounting: approx. 480 g

Standard accessories

Cable glands
Installation material
Operating manual

Approvals/approval marks

Mark of conformity	Testing laboratory	Certificates/certification numbers	Test basis	valid for
c UL us	Underwriters Laboratories	E 201387	UL 61010-1	all versions

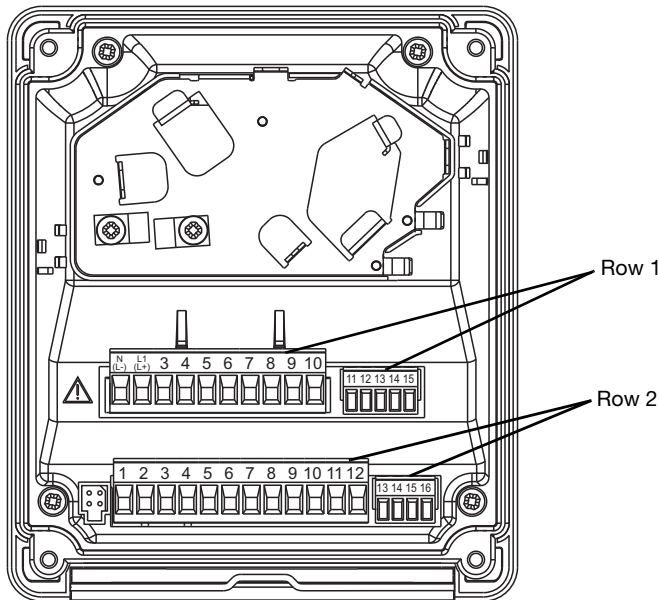

Connection diagram



The connection diagram in the data sheet provides preliminary information about the connection options. For the electrical connection, only use the installation instructions or the operating manual. The knowledge and the correct technical execution of the safety information/instructions contained in these documents are mandatory for mounting, electrical connection, startup, and for safety during operation.

The connecting cable between the sensor and the transmitter must be a shielded cable with a maximum diameter of 8 mm. There is a guide plate to ensure optimum cable routing. The cable run to the pluggable screw terminals incorporates strain relief, and the sensor cables are connected without using solder.

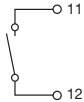
Connection		Terminal	Row
Power supply voltage for transmitter/controller			
Supply voltage (23): AC 110 to 240 V; -15/+10 %; 48 to 63 Hz		1 N (L-)	1
Supply voltage (25): AC/DC 20 to 30 V; 48 to 63 Hz		2 L1 (L+)	
Supply voltage (30): DC 12 to 24 V; +/-15 %			
NC		3	
Power supply voltage for proximity switch			
DC 12 V (10 to 20 V)		11 + 12 -	1
Power supply voltage for transmitter			
DC 24 V (-15/+20 %)		14 + 15 -	1
Inputs			
NC		1 2 3 6 7	2
Standard signal input 0(4) to 20 mA or 0 to 10 V and 10 to 0 V		4 - 5 +	
Resistance thermometer in 2-wire circuit		8 9 10	
Resistance thermometer in 3-wire circuit		8 9 10	

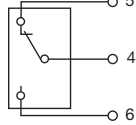
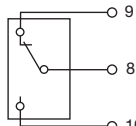
Connection		Terminal	Row
Binary input		11 12	2
Outputs			
Analog output 1 0 to 20 mA and 20 to 0 mA or 4 to 20 mA and 20 to 4 mA or 0 to 10 V and 10 to 0 V (electrically isolated)		+ 13 - 14	2
Analog output 2 0 to 20 mA and 20 to 0 mA or 4 to 20 mA and 20 to 4 mA or 0 to 10 V and 10 to 0 V (electrically isolated)		+ 15 - 16	
Switching output K1 (floating)		4 pole 5 NC 6 NO	1
NC		7	
Switching output K2 (floating)		8 pole 9 NC 10 NO	

Dimensions

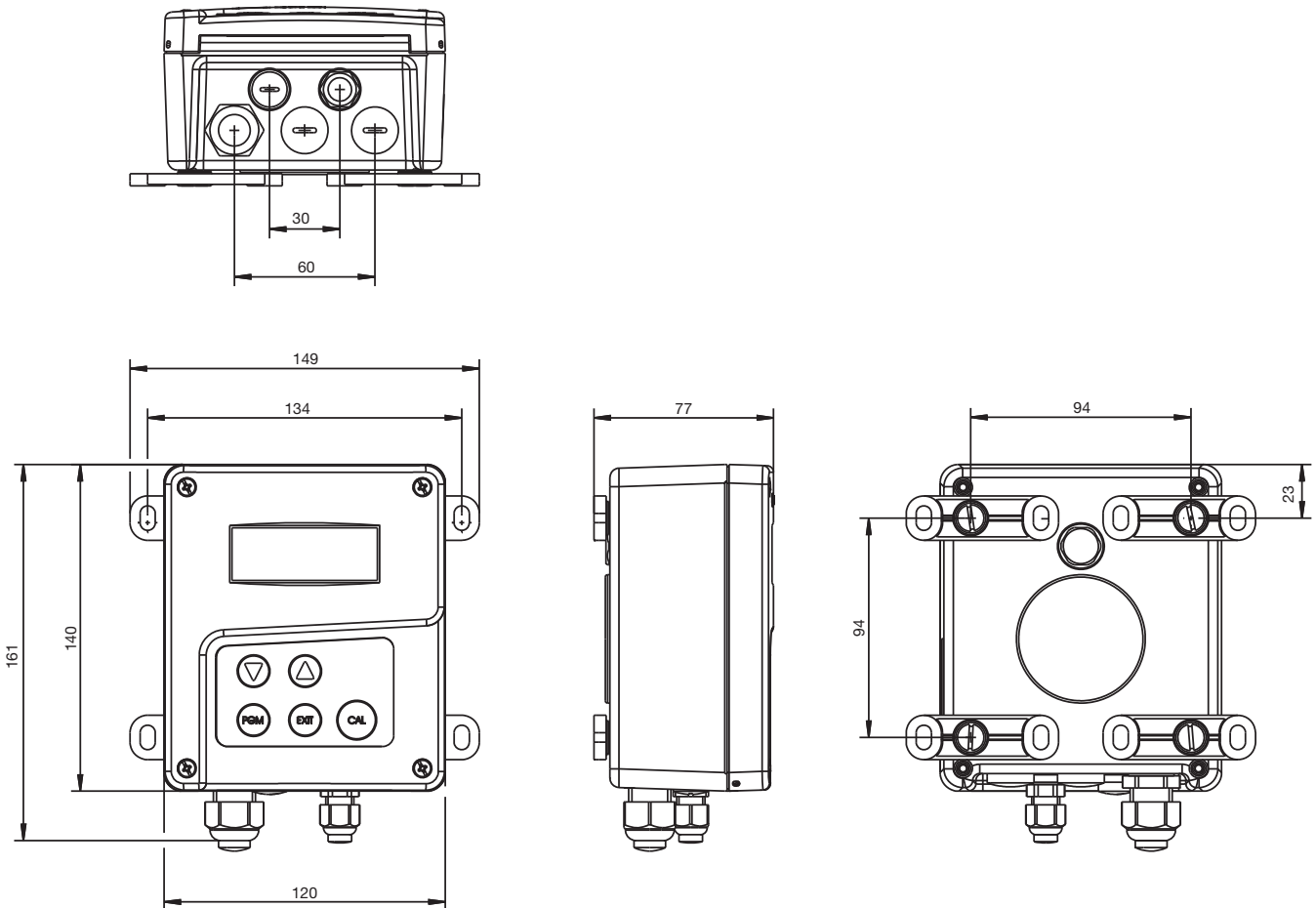

Panel mounting/drilling diagram

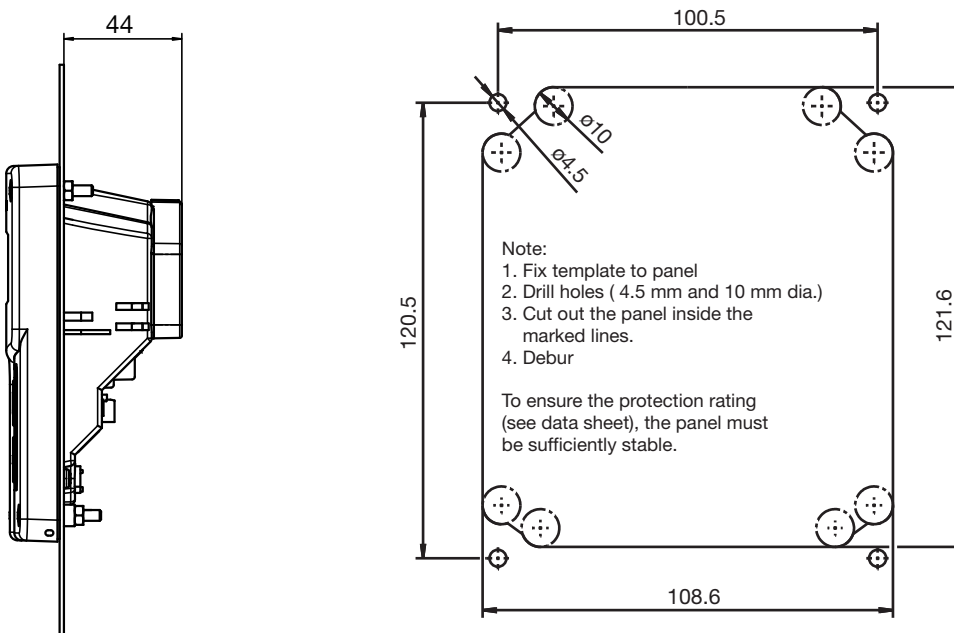

Note:
The drilling template (in actual size) is shown in the operating manual B 202568.0

Accessories

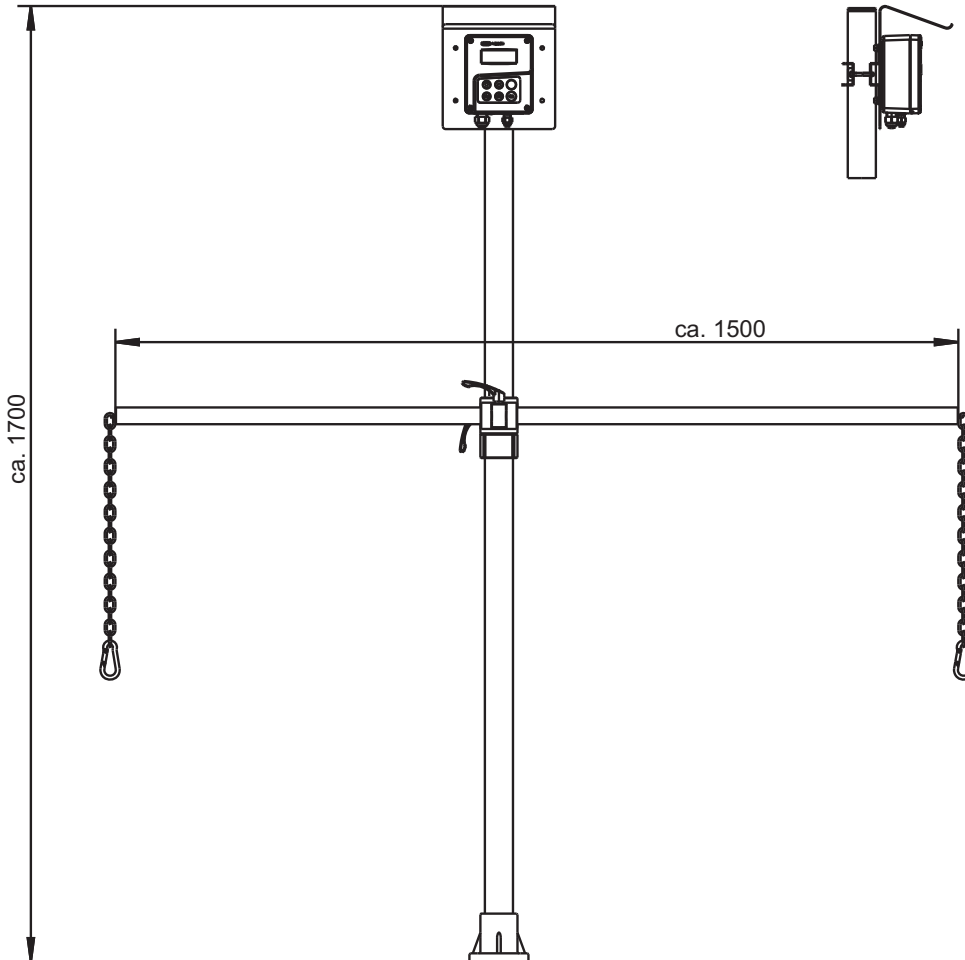

Support pillar with base, arm and chain
Part no.: 00398163

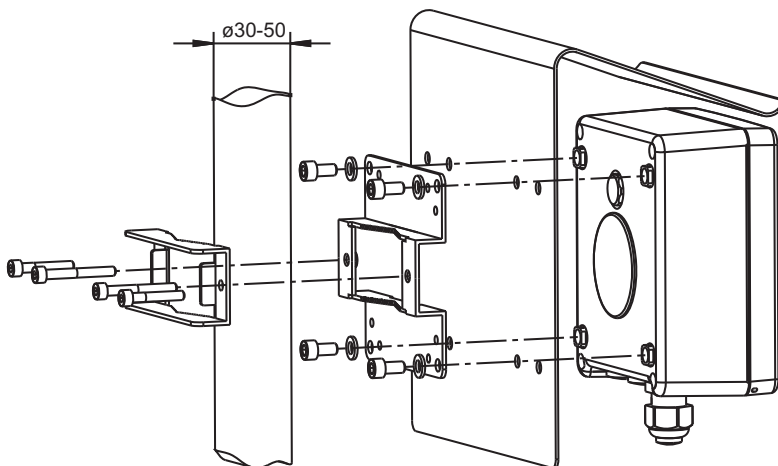

Pipe installation set for JUMO AQUIS 500
Part no.: 00483664
Protective roof for JUMO AQUIS 500
Part no.: 00398161

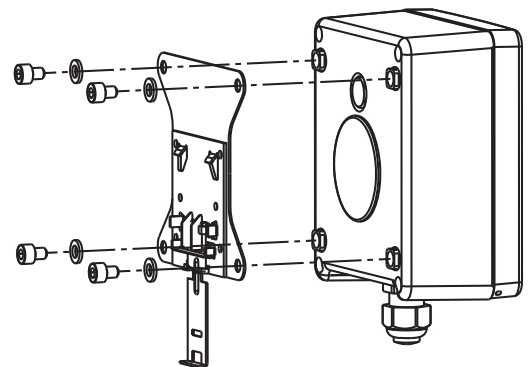

DIN rail installation set for JUMO AQUIS 500
for mounting the instrument on a 35 mm x 7.5 mm DIN
rail as per EN 60715 A.1
Part no.: 00477842

Application examples

Indicator/controller for pH

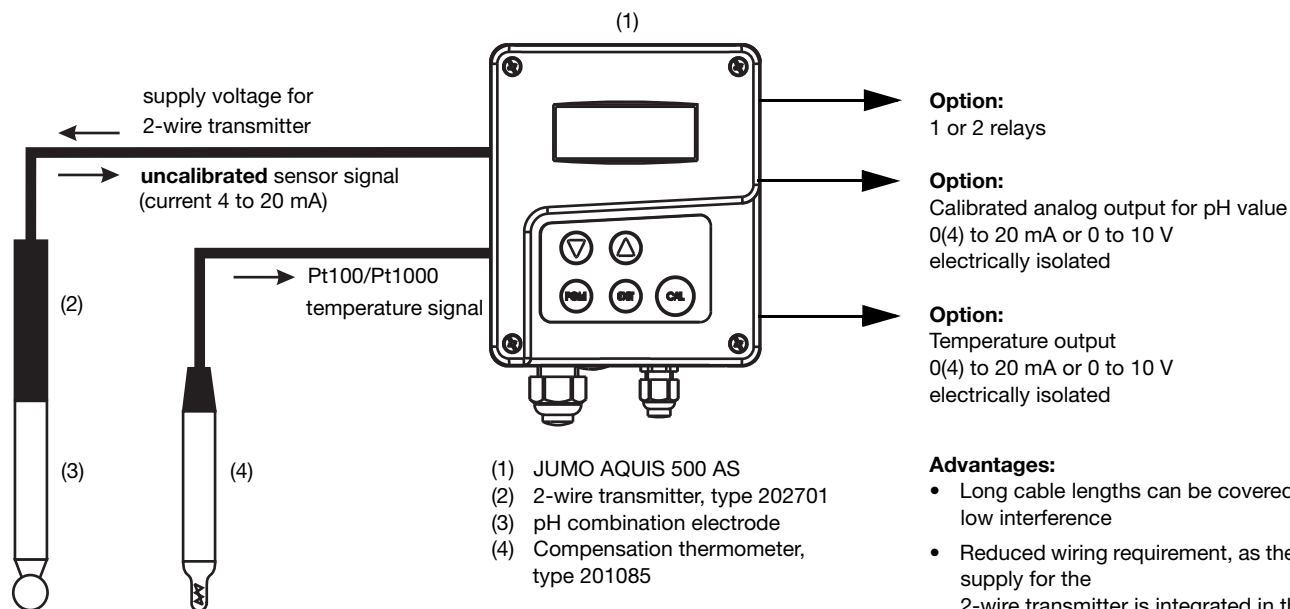

Indicator/controller for free chlorine, chlorine dioxide, hydrogen peroxide, peracetic acid or ozone

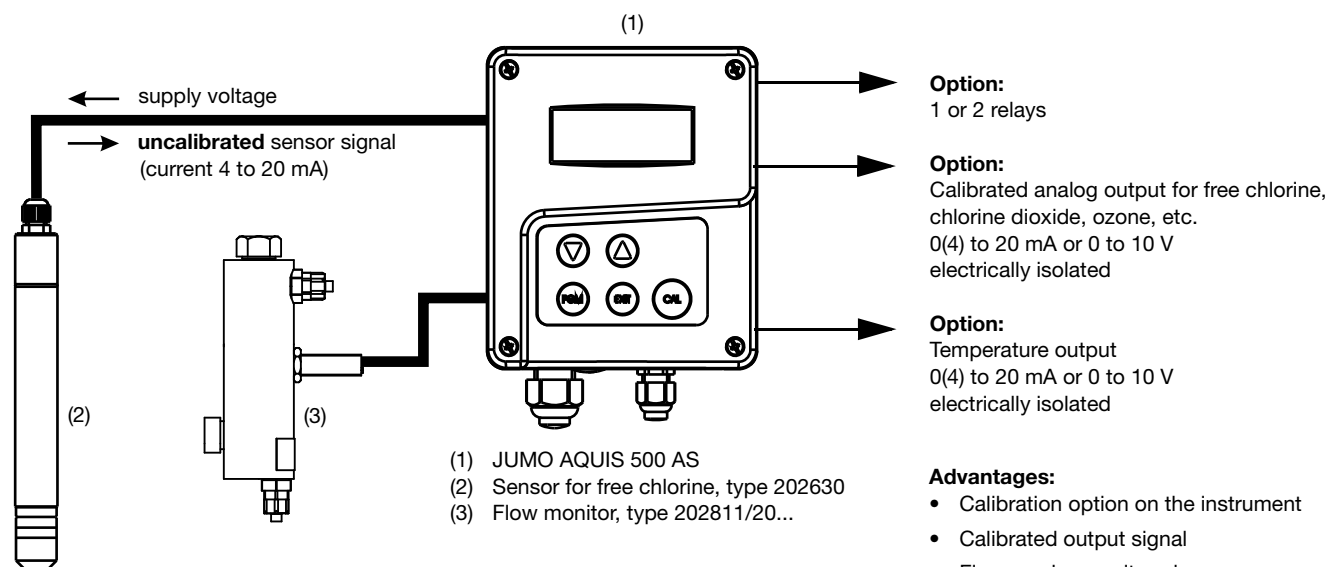

Indicator/controller for level or liquid level

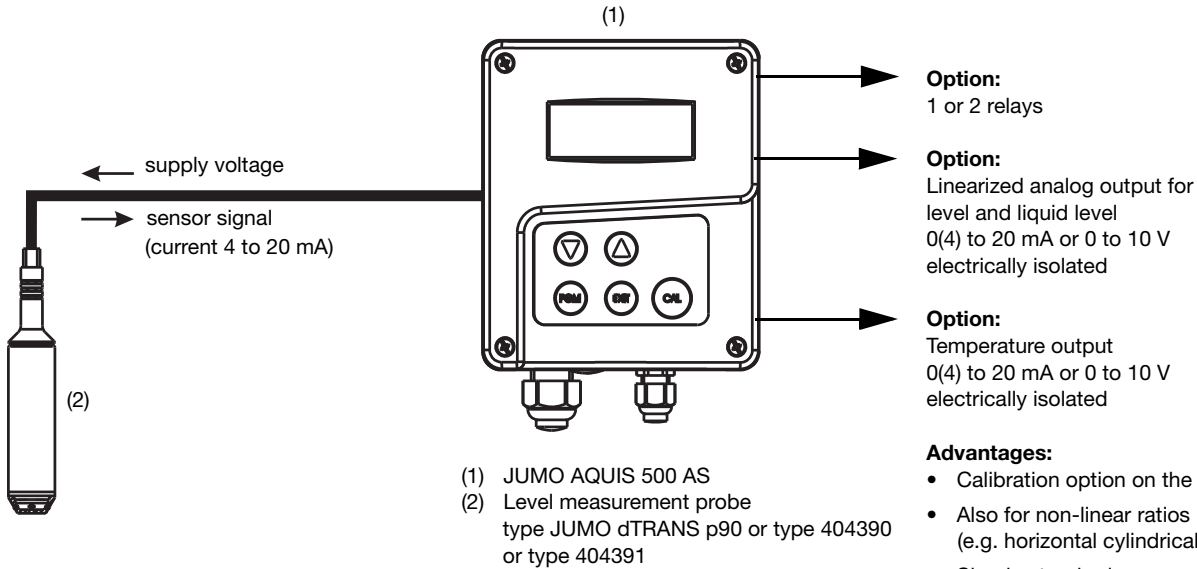

¹ The setup program, which is available as an option, can be used to linearly assign a display in liters or similar, to a non-linear input variable such as the liquid level of a horizontal, cylindrical tank (20 value pairs)

Indicator/controller for flow rate

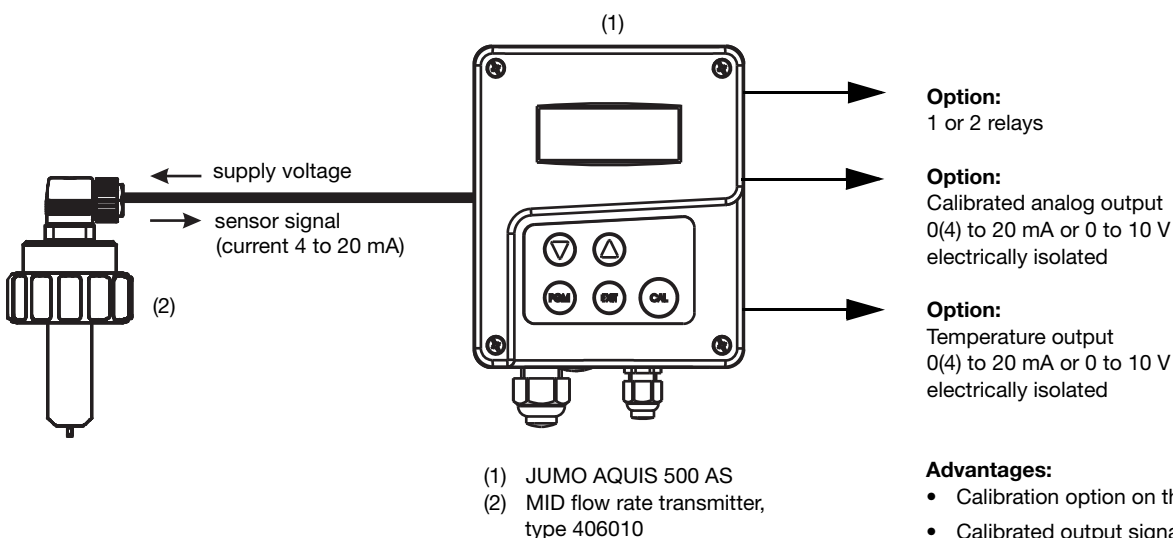



Order Details

(1) Basic type	
202568	JUMO AQUIS 500 AS Indicator/controller for standard signals in analytical systems
(2) Basic type extension	
10	For panel mounting
20	In surface mountable housing
(3) Input (freely configurable)	
888	0(4) to 20 mA and 0 to 10 V
(4) Output 1 (for main value or continuous controller)	
000	No output
888	Analog output 0(4) to 20 mA and 0 to 10 V
(5) Output 2 (for temperature or continuous controller)	
000	No output
888	Analog output 0(4) to 20 mA and 0 to 10 V
(6) Output 3	
000	No output
310	Relay with changeover contact
(7) Output 4	
000	No output
310	Relay with changeover contact
(8) Supply voltage	
23	AC 110 to 240 V, +10%/-15 %, 48 to 63 Hz
25	AC/DC 20 to 30 V, 48 to 63 Hz
30	DC 12 to 24 V, ±15 %
(9) Extra codes	
000	None

Order code (1) (2) (3) (4) (5) (6) (7) (8) (9)
 / - - - - - - - /
 Sample order 202568 / 20 - 888 - 888 - 000 - 310 - 000 - 23 / 000



Stock versions

(delivery 3 days after receipt of order)

Type	Part no.
202568/20-888-888-888-310-310-23/000	00528718
202568/20-888-888-000-310-000-23/000	00528719

Accessories

(delivery 10 days after receipt of order)

Type	Part no.
Protective roof for JUMO AQUIS 500 ^a	00398161
Pipe installation set for JUMO AQUIS 500 ^b	00483664
DIN rail installation set for JUMO AQUIS 500 ^c	00477842
Support pillar with base clamp, arm and chain	00398163
Holder for suspension fitting	00453191
Back panel set 202560/65	00506351
PC setup software	00483602
PC interface cable including USB/TTL converter and two adapters (USB connecting cable)	00456352

^a The pole-mounting kit is needed for mounting the protection cover

^b With the pipe installation set, the JUMO AQUIS 500 can be attached to a pipe (e. g. a support pillar or a railing)

^c With the DIN rail installation set, the JUMO AQUIS 500 can be attached to a 35 mm × 7.5 mm DIN rail as per EN 60715 A.1