

JUMO ecoLine O-DO

Optical Sensor for Dissolved Oxygen

Brief description

The JUMO ecoLine O-DO is an optical sensor designed to measure dissolved oxygen in aqueous solutions. Its measuring method, accredited according to ASTM D888-05, is based on the principle of **luminescence quenching** and offers the following advantages:

- Low operating costs due to reduced maintenance work (no electrolyte changes)
- Greater calibration intervals due to low drift behavior
- No polarization voltage required
- High measuring accuracy, even for low concentrations
- Rapid response time, no minimum inflow (no oxygen consumption)

The sensor features excellent interference immunity thanks to the integrated preamplifier and digital signal processing. The measured value for dissolved oxygen is automatically compensated with the temperature, air pressure, and salinity (salt content), and transferred without interference to the connected display unit and controller via a digital interface.

The optical membrane cap is easy to replace, meaning the sensor is very easy to maintain. The current calibration data is saved directly in the sensor electronics. As a result, the Plug and Play function of the system is enabled without the need for recalibration. The sensor also includes a log book containing the last 10 successful calibrations in the form of a ring buffer.

The compact, robust stainless steel sensor is particularly well suited to the following typical applications:

- Industrial and municipal sewage treatment plants
- Wastewater management (nitrification, de-nitrification)
- Surface water monitoring
- Fish farming, aquaculture
- Drinking water monitoring



Type 202613/...

Technical data

Specifications

Measuring principle	Optical measurement according to the principle of luminescence quenching
Measurands	Dissolved oxygen Temperature
Measuring range	0.00 to 20.00 mg/l 0.00 to 20.00 ppm 0 to 200 % SAT
Resolution	0.01
Accuracy	±0.1 mg/l ±0.1 ppm ±1 % SAT
Response time	$t_{90} < 60$ s
Luminophore operating life (DO Disk)	Approx. 2 years depending on the sampling rate of the display unit and the process conditions
Temperature compensation	Via integrated NTC, in the range from 0 to +40 °C
Air pressure compensation	500 to 1100 hPa (entered on display unit / controller)
Salinity compensation	0 to 60 g/kg (entered on display unit / controller)
Max. sampling rate for measured values	1 Hz

Interfaces

Signal interface	RS485 interface with Modbus RTU protocol ^a
------------------	---

^a Only in connection with suitable Modbus master devices, see "Display unit/controller" on page 2.

Electrical data

Voltage supply	DC 5 to 12 V
Current consumption	
Standby	25 μ A
RS485 on average	4.4 mA (at 1 measurement/s)
Current pulse (starting current peak)	100 mA
Connection	4-conductor shielded cable, open conductor ends with ferrules
Electromagnetic compatibility	According to EN 61326-1
Interference emission	Class A
Interference immunity	Industrial requirements ^a

^a Sensor is not protected against surge voltages.

Environmental conditions

Inflow	An inflow is not required, but is useful and recommended to prevent a build-up of dirt
Admissible storage temperature	-10 to +60 °C
Admissible ambient temperature	-5 to +60 °C
Admissible process temperature	0 to +50 °C
Admissible process pressure	Max. 5 bar

Case

Dimensions	Ø 25 mm × 146 mm
Weight	
Sensor including 10 m cable	827 g
Sensor including 30 m cable	1984 g
Admissible cable length	Max. 30 m
Material	
Sensor shaft and membrane cap	Stainless steel 316L
Cable bushing	Polyamide
Membrane	Silicone
Precautionary measures when using the product	The membrane is susceptible to chemicals (organic solvents, acids, peroxides) and mechanical influences (impacts, abrasion, cracks)
Protection type	IP68

Display unit / controller

 <p>The image shows a blue JUMO AQUIS 500 RS display unit. The top of the unit has the JUMO logo and 'AQUIS 500'. Below that is a yellow LCD screen displaying 'MESSUNG 10.51' and '21.6 °C 09/1'. At the bottom of the unit, there are three buttons labeled 'PGM', 'EXIT', and 'CAL'. The unit has a rugged, industrial design with four screws on the top and bottom edges.</p>	<p>JUMO AQUIS 500 RS display unit / controller, type 202569/... For this, see data sheet 202569</p>
--	---

Dimensions

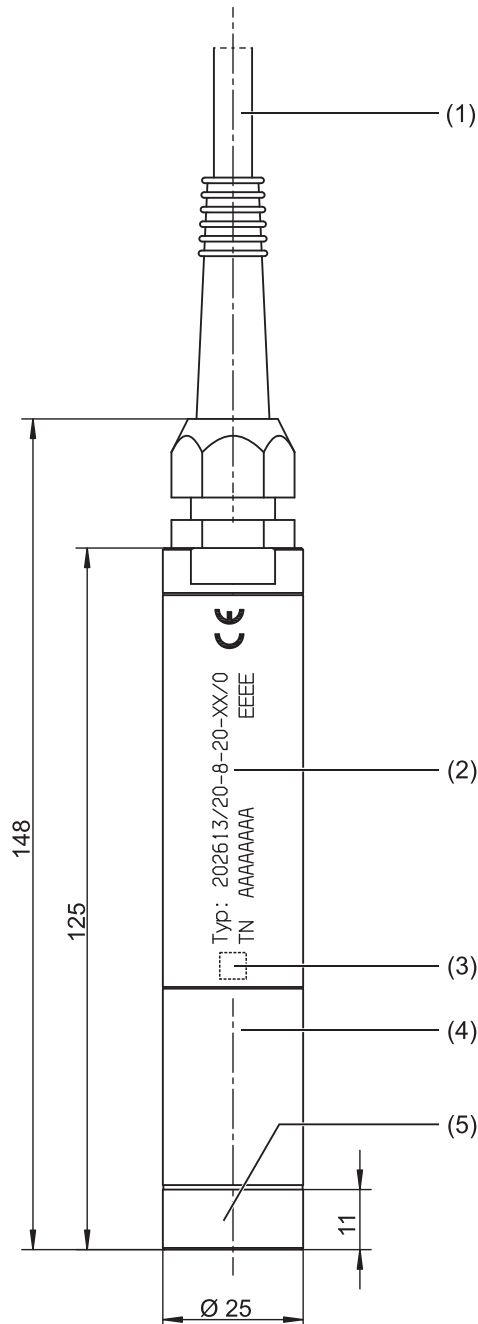

- (1) RS485 connection cable
- (2) Laser engraving indicating the sensor type and part no.
- (3) QR code
- (4) Sensor body with evaluation electronics
- (5) Removable membrane cap with luminophore

Electrical connection

The cables with conductor end sleeves are connected without tension or soldering, using screw-type plug-in terminals such as on the JUMO AQUIS 500 RS (type 202569/...) display unit/controller.

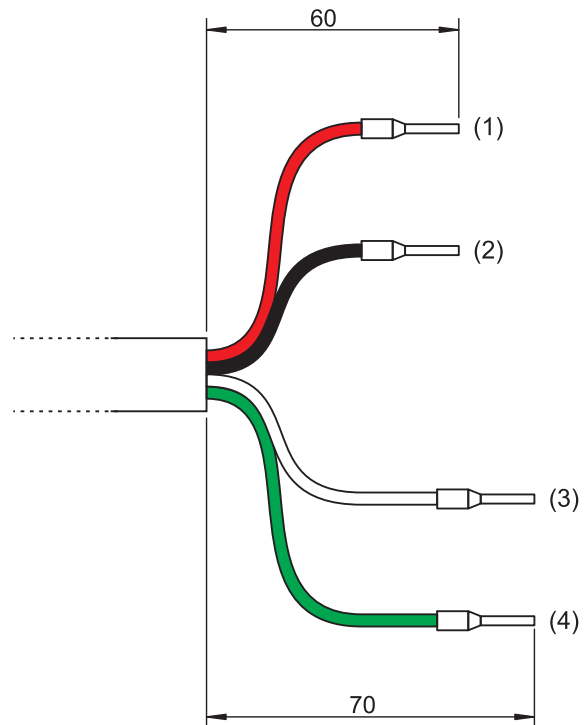

- (1) Red Voltage supply +
- (2) Black Voltage supply -
- (3) White RS485 +
- (4) Green RS485 -

Measuring point set-up

The set-up of a complete measuring system for measuring dissolved oxygen is shown below. The figure shows a support pillar with pedestal base, cantilever arm, and chain. A JUMO AQUIS 500 RS is used as a display unit / controller, which is mounted on the support pillar and protected by a weather protection canopy (see chapter „Accessories“, page 10).

The suspended fitting in image **A** is attached to the cantilever arm by a chain. Alternatively, an immersion fitting can also be attached to the cantilever arm using a cross clamp, see image **B**.

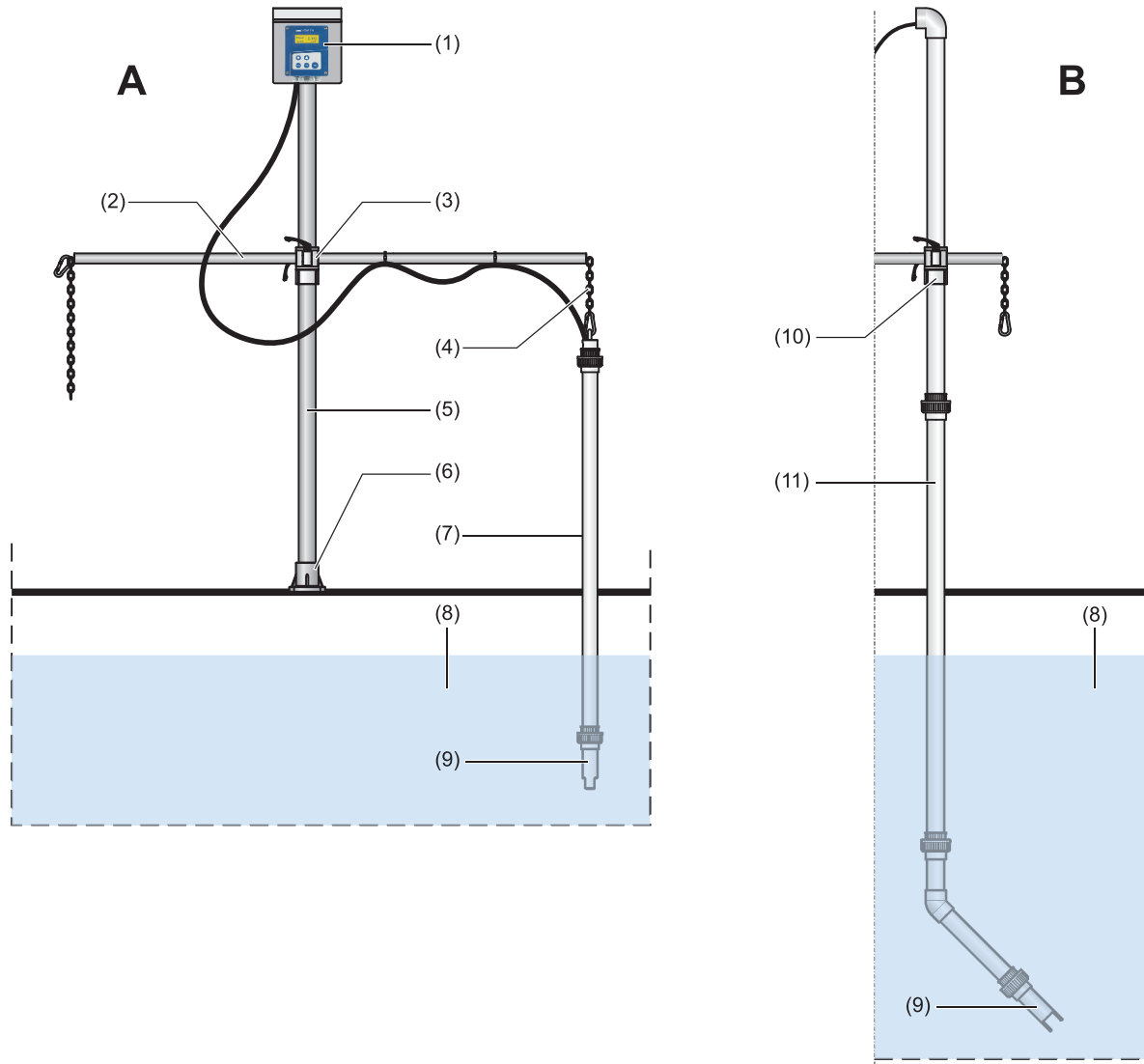

- | | | |
|------|--|--|
| (1) | JUMO AQUIS 500 RS display unit / controller, type 202569/... | } Support pillar with pedestal base,
cantilever arm, and chain
Part no. 00398163 |
| (2) | Cantilever arm, adjustable | |
| (3) | Cross clamp with 2 clamping levers | |
| (4) | Chain | |
| (5) | Support pillar | |
| (6) | Pedestal base | |
| (7) | Suspended fitting including sensor mounting (9), part no.: 00601881 | |
| (8) | Basin/tank/container | |
| (10) | Cross clamp for support pillar (part no. 00605468), required to attach the immersion fitting | |
| (11) | Angled immersion fitting including sensor mounting (9), part no.: 00605469 | |

Accessories

Suspended fitting

The suspended fitting holds the JUMO ecoLine O-DO oxygen sensor and is primarily used to take measurements from open basins. It can be positioned a considerable distance from the basin edge with the bracket suspended on a chain, for example. Different immersion depths are possible through the use of different immersion pipe lengths. Please note the following when planning your set-up:

- The fitting must be easily accessible to allow the sensor and the fitting itself to be maintained and cleaned regularly.
- Do not allow the fitting (and thus also the sensor) to swing against and hit the basin edge.
- When working with systems involving pressure and/or temperature, ensure that the fitting and sensor meet all relevant requirements.
- The system designer must check that the materials in the fitting and sensor are suitable for the measurement (chemical compatibility, for instance).

Suspended fitting	
Materials	Pipe: PVC Sensor mounting: PVC
Temperature range	0 to 60 °C
Pressure range	Up to 5 bar
Total length	1549 mm
Part no.	00601881

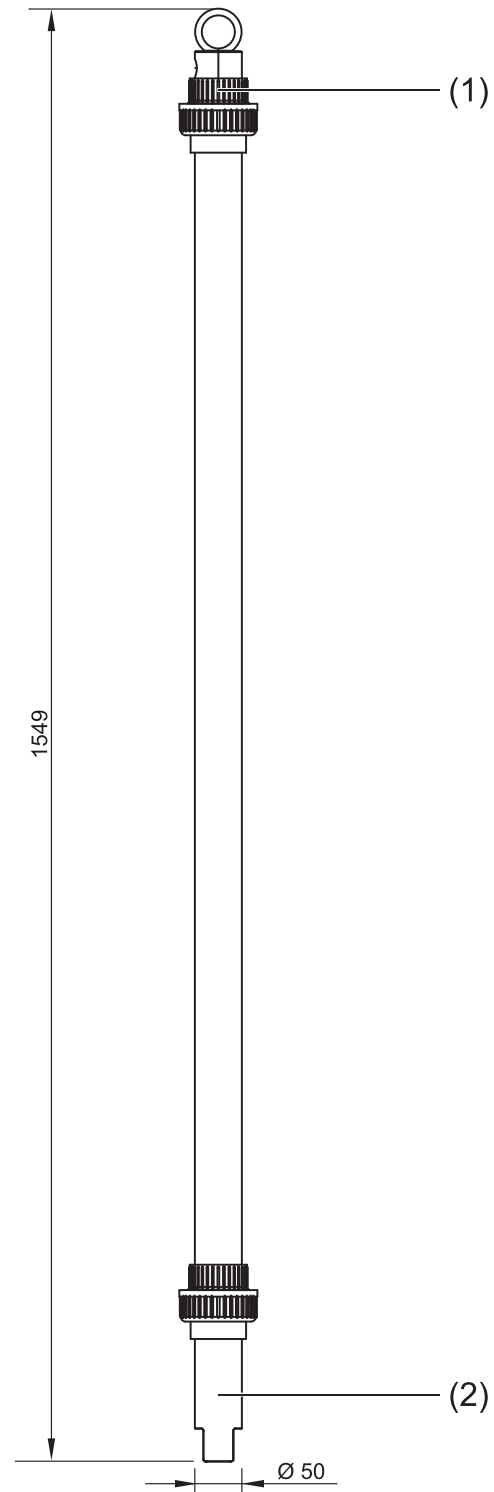

- (1) Fastener with chain holder
(2) Sensor mounting

Immersion fitting

The immersion fitting holds the JUMO ecoLine O-DO oxygen sensor. It is curved at the bottom end and is primarily used for taking measurements from aeration basins. It protects the sensor and enables measurements at different immersion depths. The fitting is attached to a support pillar using a cross clamp, see chapter „Measuring point set-up“, page 5.

Alongside the standard version with a total length of 3,106 mm, shorter versions are also available on request.

Please note the following when planning your set-up:

- The fitting must be easily accessible to allow the sensor and the fitting itself to be maintained and cleaned regularly.
- Do not allow the fitting (and thus also the sensor) to swing against and hit the basin edge.
- When working with systems involving pressure and/or temperature, ensure that the fitting and sensor meet all relevant requirements.
- The system designer must check that the materials in the fitting and sensor are suitable for the measurement (chemical compatibility, for instance).

Immersion fitting		
Materials	Pipe: PVC Sensor mounting: PVC	
Temperature range	0 to 60 °C	
Pressure range	Up to 5 bar	
Total length	3,106 mm	Other lengths on request
Part no.	00605469	

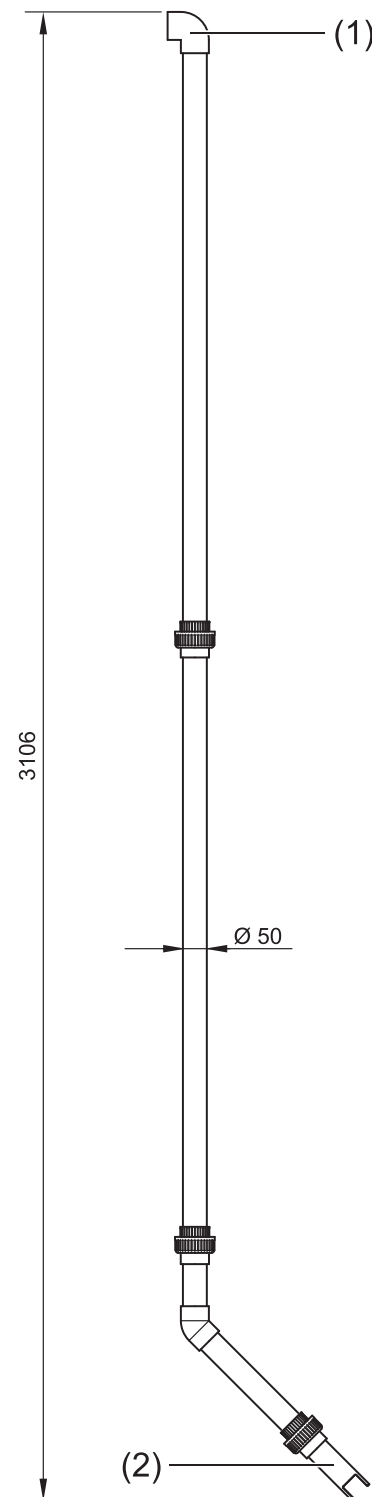

- (1) Angled end piece
(2) Sensor mounting

Flow fitting

The flow fitting holds the JUMO ecoLine O-DO oxygen sensor and is mounted directly in the supply line for the medium being measured or in the bypass. Its special design type ensures the correct inflow to the sensor, thus preventing incorrect measurements. Please note the following when planning your piping set-up:

- The fitting must be easily accessible to allow the sensor or the fitting itself to be maintained and cleaned regularly
- We recommend bypass measurements. It must be possible to remove the sensor through the use of shut-off valves
- When working with systems involving pressure and/or temperature, ensure that the fitting and sensor meet all relevant requirements
- The system designer must check that the materials in the fitting and sensor are suitable for the measurement (chemical compatibility, for instance)

PVC flow fitting, angled seat	
Material	PVC
Admissible temperature	0 to 60 °C
Pressure resistance	Up to 5 bar
Connection	Bonded sockets
Process connection	T-piece DN 50, 45°
Part no.	00601909

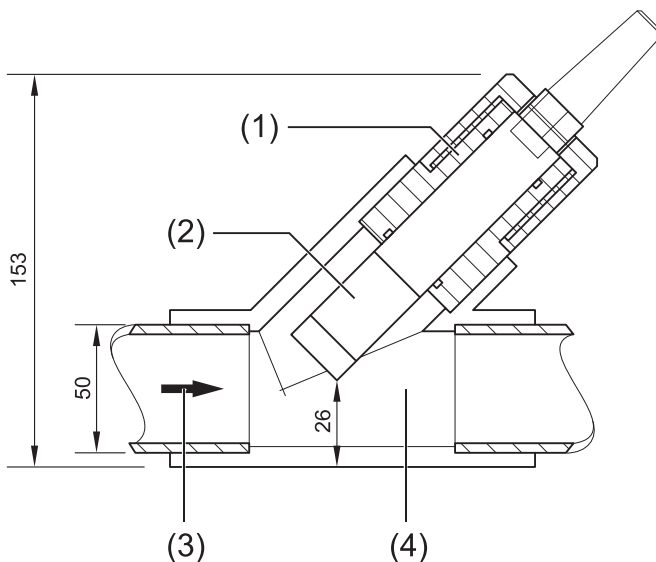

- (1) Mounting adapter for sensor
- (2) JUMO ecoLine O-DO sensor
- (3) Flow direction
- (4) T-piece DN 50, 45°, PVC



Order details

(1) Basic type	
202613	JUMO ecoLine O-DO Optical oxygen sensor
(2) Basic type extension	
20	Standard, 0 to 20 ppm
(3) Version	
8	Standard with factory settings
(4) Electrical connection	
20	Fixed cable
(5) Length of permanent cable	
10	10 m
30	30 m
(6) Extra codes	
0	Without

Order code	(1)	(2)	(3)	(4)	(5)	(6)					
	<input type="text"/>	/	<input type="text"/>	-	<input type="text"/>	-	<input type="text"/>	-	<input type="text"/>	/	<input type="text"/>
Order example	202613	/	20	-	8	-	20	-	10	/	0

Important information:

The order code is not modular. When placing orders, if possible please select the items listed under "**Stock versions**" or "**Production versions**". We must check the technical feasibility of and approve freely chosen combinations of individual code parts.

Scope of delivery

Sensor with membrane cap in the version ordered
Operating manual B 202613.0
Calibration certificate

Stock version

(Delivery within 3 working days after receipt of order)

Type	Parts no.
202613/20-8-20-10/000	00598654
202613/20-8-20-30/000	00598655

Accessories

(Delivery within 10 working days after receipt of order)

Fittings

Type	Parts no.
Suspended fitting for type 202613/..., PVC, total length 1,549 mm	00601881
Immersion fitting for type 202613/..., PVC, total length 3,106 mm ^a	00605469
Flow fitting for type 202613/..., PVC, angled seat	00601909

^a Other lengths on request.

Maintenance set

Type	Parts no.
Membrane cap with luminophore for type 202613/...	00601917

Suitable display unit with controller

Type	Parts no.
JUMO AQUIS 500 RS, type 202569/...	See data sheet 202569

Accessories for AQUIS 500 RS

Type	Parts no.
Support pillar with pedestal base, cantilever arm, and chain	00398163
Additional cross clamp for support pillar, required to attach the immersion fitting	00605468
Pipe-mounted kit for AQUIS 500 RS	00398162
Weather protection canopy for AQUIS 500 RS	00398161
Setup program for JUMO AQUIS 500 on CD-ROM	00483602
PC interface TTL/RS232 converter	00301315
PC interface with USB/TTL converter, adapter (socket), and adapter (pins)	00456352