

# Air velocity and temperature transmitter

## CTV 210-R

### KEY POINTS

- Configurable ranges from 0 to 30 m/s with hot wire probe
- Configurable range from 0 to 50°C in temperature
- Airflow function
- Two 4-wire analogue output 0-5/10 V or 0/4-20 mA
- Power supply 24 Vdc/Vac or 100-240 Vac
- Trend indicator
- ABS V0 IP65 housing, with or without display
- "¼ turn" system mounting with wall-mount plate
- 2 relay outputs



### FEATURES OF THE HOUSING

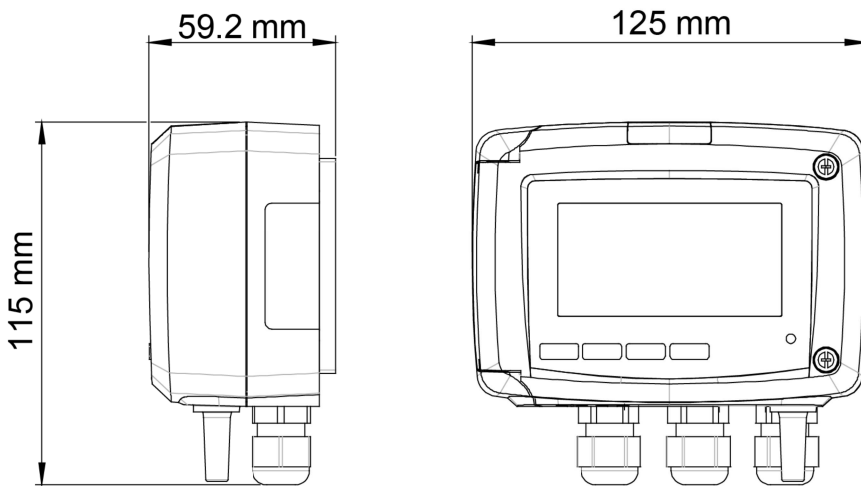

**Material:** ABS V0 as per UL94

**Protection:** IP65

**Display:** 75 x 40 mm, LCD 20 digits 2 lines.

**Height of digits:** Values: 10 mm; Units: 5 mm

**Cable gland:** For cables Ø8 mm maximum

**Weight:** 340 g

### PART NUMBER

To order, just add the codes to complete the part number:

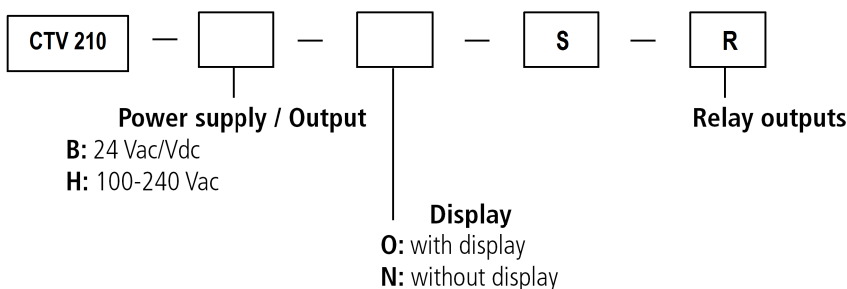

**Example: CTV210 – BOS – R**

Air velocity and temperature transmitter, power supply 24 Vac/Vdc, with display and relay outputs

## TECHNICAL FEATURES IN TEMPERATURE

<b>Measuring range</b>	From 0 to +50°C
<b>Unit of measurement</b>	°C / °F
<b>Accuracy*</b>	±0.3% of reading ±0.25°C
<b>Response time</b>	$T_{90} = 0.9$ second for $V_{air} = 1$ m/s
<b>Resolution</b>	0.1°C / 0.1°F
<b>Type of sensor</b>	Pt100 1/3 as per DIN IEC751
<b>Type of fluid</b>	Air and neutral gases

## TECHNICAL FEATURES IN AIR VELOCITY

<b>Measuring range</b>	Standard model: from 0 to 30 m/s
<b>Unit of measurement</b>	m/s, fpm, km/h
<b>Accuracy*</b>	From 0 to 3 m/s: ±3% of reading ±0.03 m/s From 3 to 30 m/s: ±3% of reading ±0.1 m/s
<b>Resolution</b>	Standard model: from 0 to 3 m/s: 0.01 m/s and from 3 to 30 m/s: 0.1 m/s
<b>Response time</b>	$T_{63} = 1.6$ s
<b>Type of fluid</b>	Clean air

\*All the accuracies indicated in this technical datasheet were stated in laboratory conditions, and can be guaranteed for measurements carried out in the same conditions, or carried out with calibration compensation.

## TECHNICAL FEATURES OF THE HOT WIRE PROBE

<b>Material of the probe</b>	Stainless steel 316 L
<b>Size</b>	Ø8 mm, length 300 mm
<b>Operating temperature</b>	From 0 to +50°C
<b>Cable</b>	PVC Ø4.8 mm, length 2 m



## FUNCTION

Class 210 transmitters have two analogue outputs which correspond to the two parameters displayed. It is possible to activate one or two outputs and for each output, to select between air velocity, temperature and air flow.

<i>Function</i> \ <i>Features</i>	<b>Measuring ranges</b>	<b>Units and resolutions</b>
<b>Air flow</b>	From 0 to 99 999 dam <sup>3</sup> /h (according to air velocity and duct dimension)	1m <sup>3</sup> /h – 0.1 m <sup>3</sup> /s – 1 dam <sup>3</sup> /h 0.1l/s – 1 cfm

## TECHNICAL SPECIFICATIONS

### Power supply

24 Vac / Vdc ±10%  
100-240 Vac, 50-60 Hz

**Warning: risk of electric shock**



### Output

2 x 4-20 mA or 2 x 0-20 mA or 2 x 0-5 V or  
2 x 0-10 V (4 wires)

Common mode voltage <30 Vac

Maximum load: 500 Ohms (0/4-20 mA)

Minimum load: 1 K Ohms (0-5/10 V)

2 changeover relays 3 A / 230 V

### Galvanic isolation

Inputs and outputs (models 100-240 Vac)

Device fully protected by DOUBLE ISOLATION  
or REINFORCED ISOLATION

Outputs (models 24 Vac/Vdc)



### Consumption

CTV210-B: 6 VA

CTV210-H: 8 VA

### European directives

2014/30/EU EMC; 2014/35/EU Low Voltage;  
2011/65/EU RoHS II; 2012/19/EU WEEE

### Electrical connection

Screw terminal block for cable 2.5 mm<sup>2</sup>

Carried out according to the code of good  
practice

### PC communication

USB-Mini Din cable

### Environment

Air and neutral gases

### Type of fluid

Air and neutral gases

### Conditions of use (°C/%RH/m)

From -10 to +50°C. In non-condensing  
condition. From 0 to 2000 m.

### Storage temperature

From -10 to +70°C

### Security

Protection class II; Pollution degree 2;

Overvoltage category 2 (OVCI)

# CONNECTIONS

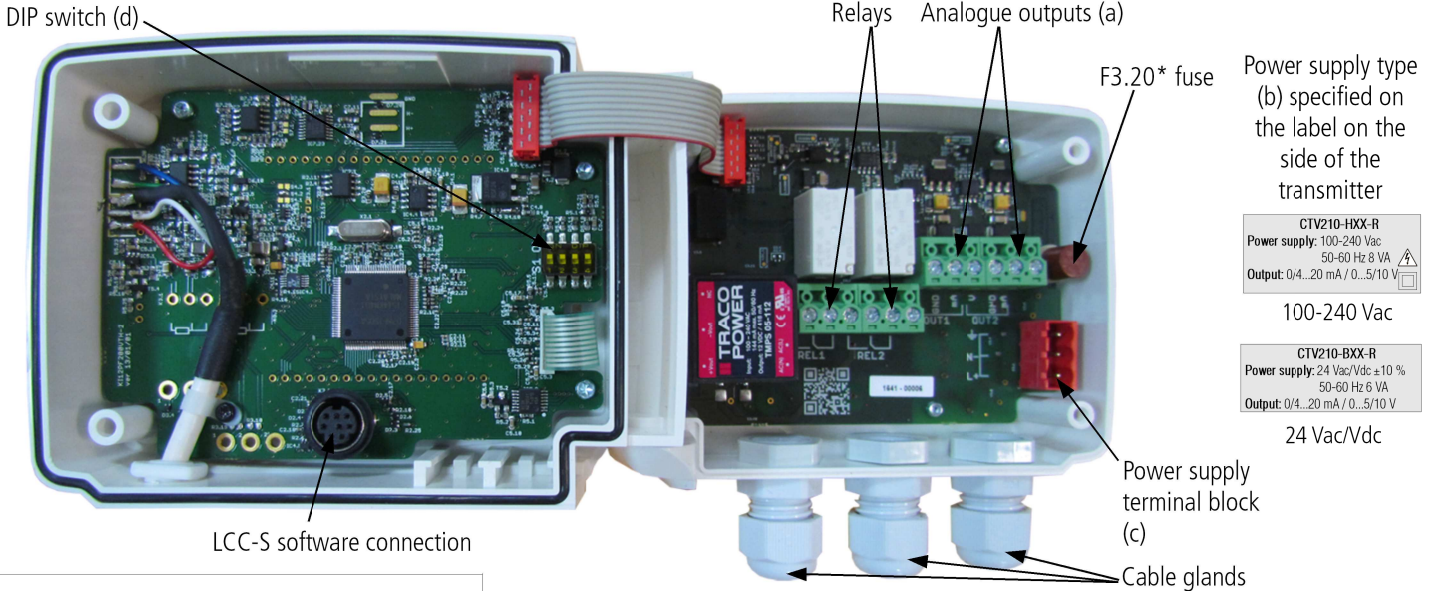

Power supply type (b) specified on the label on the side of the transmitter

**CTV210-HXX-R**  
 Power supply: 100-240 Vac  
 50-60 Hz 6 VA  
 Output: 0/4...20 mA / 0...5/10 V

100-240 Vac

**CTV210-BXX-R**  
 Power supply: 24 Vac/Vdc ±10 %  
 50-60 Hz 6 VA  
 Output: 0/4...20 mA / 0...5/10 V

24 Vac/Vdc

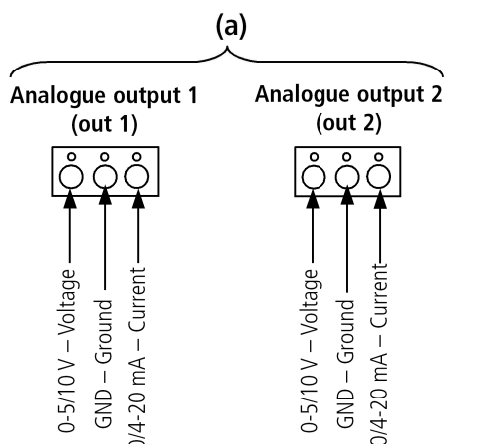

**(c)** For 24 Vdc power supply models

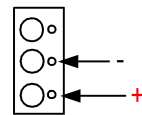

**(c)** For 24 Vac power supply models

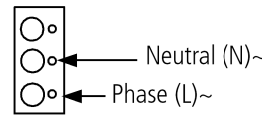

**(c)** For 100-240 Vac power supply models

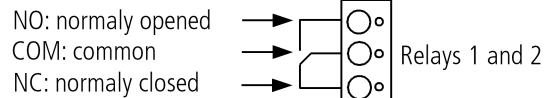
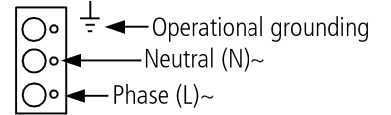

\* Fuse present only for 100-240 Vac models.  
 Every fuse replacement must be performed with a power off device using a TR5 630 mA 250 V fuse.

## ELECTRICAL CONNECTIONS – as per NFC15-100 standard

**Warning:** This connection must be made by a formed and qualified technician. To make the connection, the transmitter must not be energized. Before making the connection, you must first check the power supply indicated on the transmitter board (see (b) on "Connections" part). The presence of a switch and a circuit breaker upstream the device is compulsory

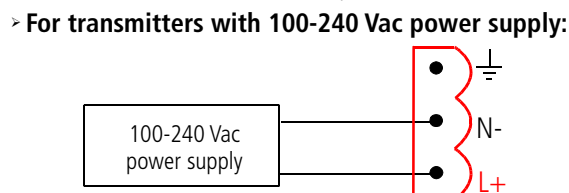
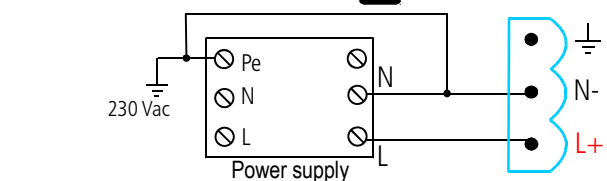
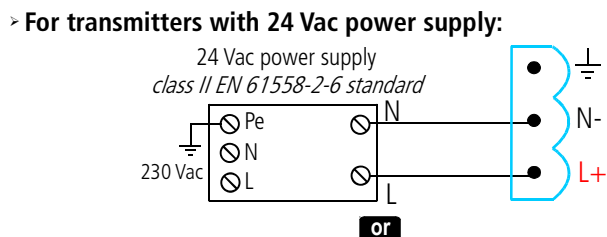
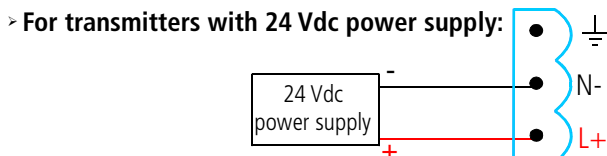

**Warning:** On 100-240 Vac models, if a fuse protection is used for the power line, it is imperative to use delayed-action fuses in order to absorb the surge of current when first turned on the transmitter.

The selection of the output signal in voltage (0-10 V or 0-5 V) or in current (4-20 mA or 0-20 mA) is made via the DIP switch (d) of the electronic board of the transmitter: put the on-of switches as shown in the table below:

Configurations	4-20 mA	0-10 V	0-5 V	0-20 mA
Combinations				

> Connection of the output in current 4-20 mA:

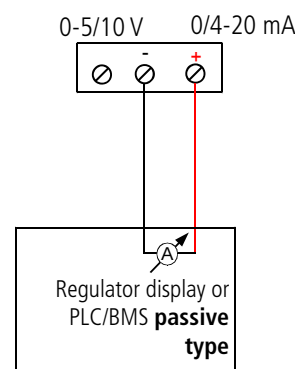

4-20 mA output

> Connection of output in voltage 0-10 V:

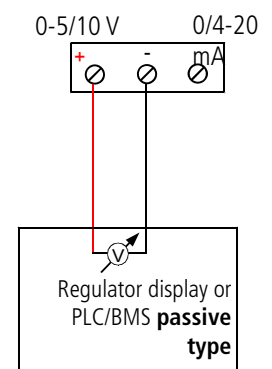

0-10 V output

## CONFIGURATION OF THE TRANSMITTERS

It is possible on the class 210 to configure all the parameters of the transmitter: units, measuring ranges, outputs, channels, calculation functions, etc, via different methods:

- **Via keypad** for models with display: a code-locking system allows to secure the installation (See class 210 transmitters user manual).
- **Via software** (optional) on all models. Simple user-friendly configuration. See LCC-S user manual.

### Configurable analogue output:

It is possible to configure your own intermediary ranges (minimum range: from 0 to 1 m/s).

**Configure the range according to your needs: outputs are automatically adjusted to the new measuring range**

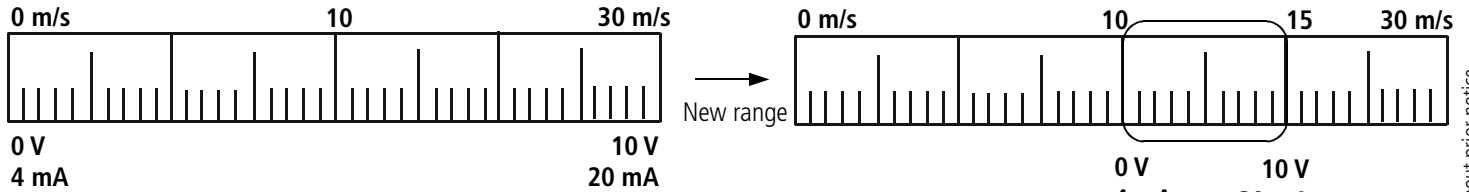

## MOUNTING

To mount the transmitter, mount the ABS plate on the wall (drilling:  $\varnothing 6$  mm, screws and pins are supplied). Insert the transmitter on the fixing plate (see A on the drawing beside). Rotate the housing in clockwise direction until you hear a "click" which confirms that the transmitter is correctly installed.

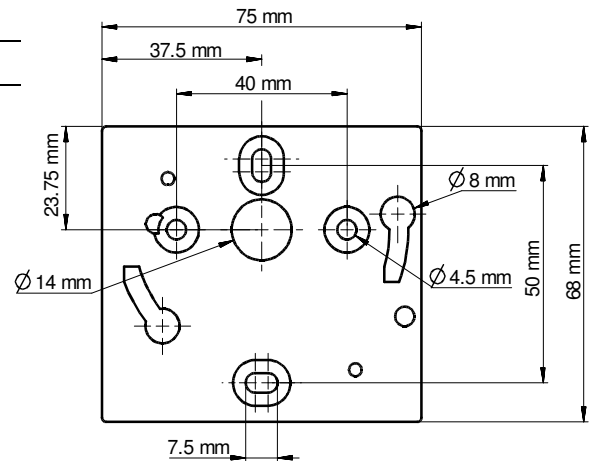

## CALIBRATION

**Outputs diagnostic:** With this function, you can check with a multimeter (or on a regulator / display, or a PLC / BMS) if the transmitter outputs work properly. The transmitter generates a voltage of 0 V, 5 V and 10 V or a current of 4 mA, 12 mA and 20 mA

**Certificate:** Class 210 transmitters are supplied with adjusting certificates. Calibration certificates are available as option.

## MAINTENANCE

Please avoid any aggressive solvent. Please protect the transmitter and its probes from any cleaning product containing formalin, that may be used for cleaning rooms or ducts.

## OPTIONS AND ACCESSORIES

- **LCC-S:** configuration software with USB cable
- **Calibration certificate**
- Sliding fittings
- Mounting brackets
- Clean spray for hotwire probe



**Only the accessories supplied with the device must be used.**

## PRECAUTIONS FOR USE

Please always use the device in accordance with its intended use and within parameters described in the technical features in order not to compromise the protection ensured by the device.



Once returned to KIMO, required waste collection will be assured in the respect of the environment in accordance with European guidelines relating to WEEE.

# 大華高科股份有限公司

[www.taiwah.com.tw](http://www.taiwah.com.tw) [info@taiwah.com.tw](mailto:info@taiwah.com.tw)

台北 TEL: (02) 2592 - 5119 Fax: (02) 2592- 3577

台中 TEL: (04) 2707 - 2269 Fax: (04) 2707- 1799

台南 TEL: (06) 243 - 2338 Fax: (06) 243 - 2339

KIMO® 為 KIMO 儀器公司的註冊商標。

資料中任何商標和圖片為本公司版權所有。未經本公司書面許可不得以任形式複製、轉印、發行或儲存資料中所包含的訊息。本資料如有變更，恕不另行通知。