

Humidity and temperature transmitter

TH 210-R

KEY POINTS

- Stainless steel or polycarbonate probe
- Two 4-wire analogue output 0-5/10 V or 0/4-20 mA
- Power supply 24 Vdc/Vac or 100-240 Vac
- Trend indicator
- ABS V0 IP65 housing, with or without display
- "¼ turn" system mounting with wall-mount plate
- Calculated parameters absolute humidity, dew point, combination ratio, wet temperature and enthalpy
- 2 relay outputs



FEATURES OF THE HOUSING

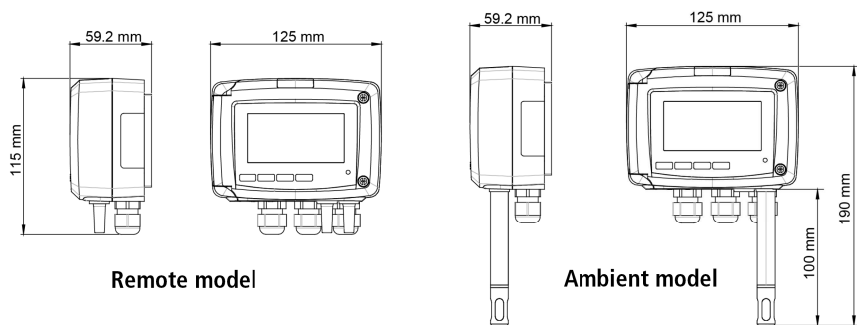

Material: ABS V0 as per UL94
Protection: IP65
Display: 75 x 40 mm, LCD 20 digits 2 lines.
Height of digits: Values: 10 mm; Units: 5 mm
Cable gland: For cables Ø8 mm maximum
Weight: 340 g

PART NUMBER

To order, just add the codes to complete the part number:

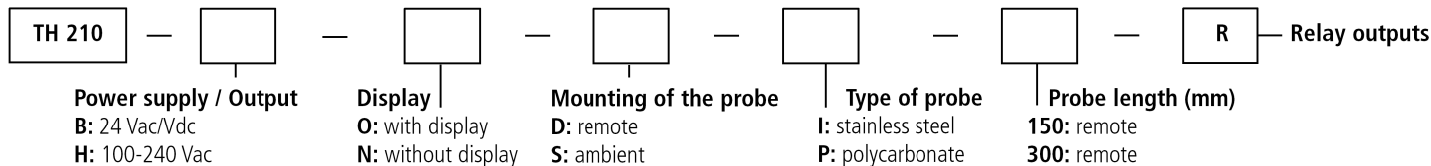

Example: TH210 – BNDP150 – R: Temperature and humidity transmitter, 24 Vac/Vdc power supply, without display, with remote probe in polycarbonate of 150 mm length and relay outputs.

Important note: the TH210 – H model (100-240 Vac) is available only with display.

TECHNICAL FEATURES IN HUMIDITY

Parameter	Measuring range	Accuracy ²	Resolution
Relative humidity (% RH)	From 0 to 100% RH	Hygrometry: - Accuracy (Repeatability, linearity, hysteresis): ±1.5% RH (from 15°C to 25°C) - Factory calibration uncertainty: ±0.88% RH - Temperature dependence: ±0.04 x (T-20)% RH (if T<15°C or T>25°C)	0.1% RH
Wet temperature ¹ (°C _{tw} , °F _{tw})	From -50 to 100°C _{tw}	-	0.1°C _{tw}
Dewpoint ¹ (°C _{td} , °F _{td})	From -50 to +100°C _{td}	-	0.1°C _{td}
Absolute humidity ¹ (g/m ³)	From 0 to 600 g/m ³	-	0.1 g/m ³
Enthalpy ¹ (kJ/kg)	From 0 to 15 000 kJ/kg	-	From 0 to 10 000: 0.1 kJ/kg From 10 000 to 15 000: 1 kJ/kg
Combination ratio ¹ (g/kg)	From 0 to 9999.9 g/kg	-	0.1 g/kg
Response time	< 10 seconds (from 10 to 80% RH, V _{air} = 2 m/s)		
Type of sensor	Capacitive		
Type of fluid	Air and neutral gas		

Class 210 transmitters have two analogue outputs which correspond to both displayed parameters. It is possible to activate one or two outputs and to select for each between humidity, temperature and the calculated parameters (The default configuration for the output 1 is 0-100% RH in hygrometry and 0-50°C in temperature for the output 2).

¹ Calculated value.

² All the accuracies indicated in this technical datasheet were stated in laboratory conditions, and can be guaranteed for measurements carried out in the same conditions, or carried out with calibration compensation.

TECHNICAL FEATURES IN TEMPERATURE

Measuring range	Ambient model: from -20 to +80°C Remote model with polycarbonate probe: from -20 to +80°C Remote model with stainless steel probe: from -40 to +180°C
Unit of measurement	°C / °F
Accuracy*	±0.3% of reading ±0.25°C
Response time	T ₉₀ = 0.9 second for V _{air} = 1 m/s
Resolution	0.1°C
Type of sensor	Pt100 1/3 as per DIN IEC751
Type of fluid	Air and neutral gases

*All the accuracies indicated in this technical datasheet were stated in laboratory conditions, and can be guaranteed for measurements carried out in the same conditions, or carried out with calibration compensation.

TECHNICAL FEATURES OF THE PROBE

> White polycarbonate probe

Measuring range	From -20 to +80°C
Dimensions of standard probe	Ø13 mm, 100 mm length
Dimensions of remote probe	Ø13 mm, 150 or 300 mm length (other length on request)
Cable	Silicone Ø4.8 mm, length 2 m (other length on request)



Polycarbonate probes are supplied with a flow-through ABS protection tip with a stainless steel filter 25 µ (ref.: EPP2).

> 316 L stainless steel probe

Measuring range	From -40 to +180°C
Dimensions of remote probe	Ø13 mm, 150 or 300 mm length (other length on request)
Cable	Silicone Ø4.8 mm, length 2 m (other on request)



Stainless steel probes are supplied with a flow through stainless steel protection tip with a stainless steel filter 25 µ (ref.: EPI25).

> Type of tips

Specifications \ Part number	EPP2	EPI25	EPI100	EPFI	EPFT	EPH202
Tip material	ABS ⁽¹⁾	St. steel ⁽²⁾	St. steel ⁽²⁾	St. steel ⁽²⁾	PTFE ⁽³⁾	MnO ₂ ⁽⁴⁾
Filter material	St. steel	St. steel	St. steel	St. steel	PTFE	PTFE
Filter type	Meshed	Meshed	Meshed	Sintered	Sintered	Sintered
Maximum particle	25 µ	25 µ	100 µ	10 µ	50 µ	50 µ
Maximum air velocity	25 m/s	25 m/s	20 m/s	30 m/s	25 m/s	25 m/s
Maximum temperature	80°C	180°C	180°C	180°C	180°C	180°C
Relative humidity maximum	95% RH	95% RH	100% RH	90% RH	90% RH	95% RH
Length	30 mm	30 mm	30 mm	30 mm	30 mm	33 mm

Application

Application	EPP2	EPI25	EPI100	EPFI	EPFT	EPH202
HVAC air-conditioning system	x	x				
Cold storage room			x		x	
Industry	x	x	x	x	x	
Pharma plants / Microelectronics	x	x	x	x	x	x
Dryer				x	x	
Curing				x		
Swimming-pool			x			

TECHNICAL SPECIFICATIONS

Power supply

24 Vac / Vdc ±10%
100-240 Vac, 50-60 Hz

Warning: risk of electric shock

Output

2 x 4-20 mA or 2 x 0-20 mA or 2 x 0-5 V or 2 x 0-10 V (4 wires)

Common mode voltage <30 VAC

Maximum load: 500 Ohms (0/4-20 mA)

Minimum load: 1 K Ohms (0-5/10 V)

2 changeover relays 3 A / 230 V

Galvanic isolation

Inputs and outputs (models 100-240 Vac)

Device fully protected by DOUBLE ISOLATION

or REINFORCED ISOLATION

Outputs (models 24 Vac/Vdc)

Consumption

TH210-B: 6 VA

TH210-H: 8 VA

European directives

2014/30/EU EMC

2014/35/EU Low Voltage

2011/65/EU RoHS II

2012/19/EU WEEE

Electrical connection

Screw terminal block for cable 2.5 mm²

Carried out according to the code of good practice

PC communication

USB-Mini Din cable

Environment

Air and neutral gases

Type of fluid

Air and neutral gases

Conditions of use (°C/%RH/m)

From -10 to +50°C. In non-condensing condition. From 0 to 2000 m.

Storage temperature

From -10 to +70°C

Security

Protection class II

Pollution degree 2

Overvoltage category 2 (OVCI)

External aggression:

Tips protect against the following external aggressions:

- **Water droplets:** EPFT
- **Shaving:** EPI25 et EPFI
- **Dust:** EPFI
- **Chemical product and grease:** EPFT
- **H₂O₂ (hydrogen peroxide):** EPH202

⁽¹⁾ **ABS:** white acrylonitrile butadiene styrene

⁽²⁾ **Stainless steel:** 316 L

⁽³⁾ **PTFE:** white Polytetrafluoroethylene

⁽⁴⁾ **MnO₂:** manganese dioxide

CONNECTIONS

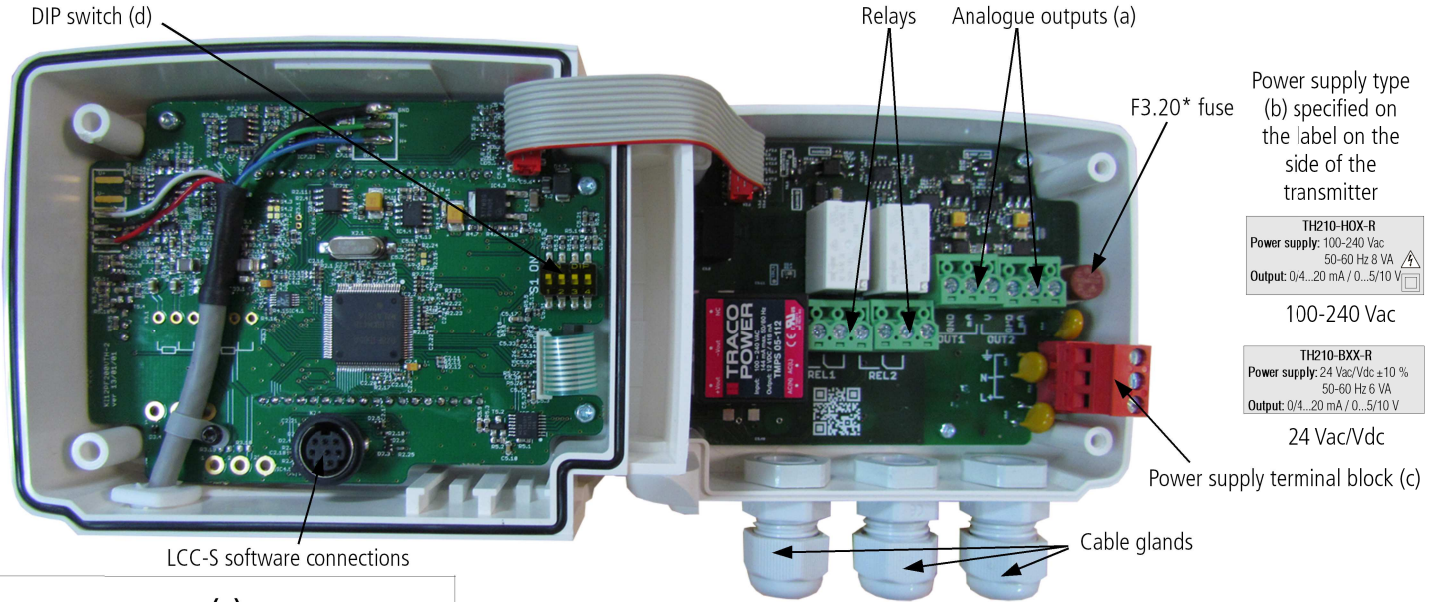

Power supply type (b) specified on the label on the side of the transmitter

TH210-HOX-R
Power supply: 100-240 Vac
50-60 Hz 6 VA
Output: 0/4...20 mA / 0...5/10 V

100-240 Vac

TH210-BXX-R
Power supply: 24 Vac/Vdc ±10 %
50-60 Hz 6 VA
Output: 0/4...20 mA / 0...5/10 V

24 Vac/Vdc

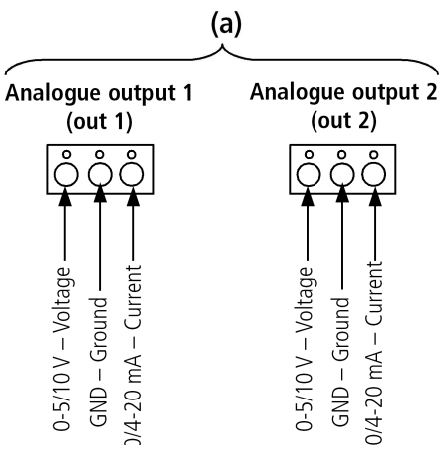

(c) For 24 Vdc power supply models

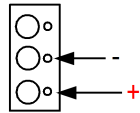

or (c) For 24 Vac power supply models

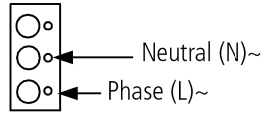

or (c) For 100-240 Vac power supply models

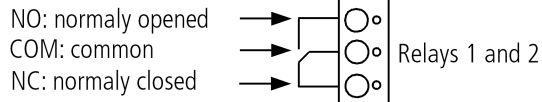
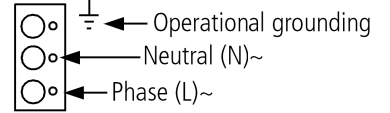

* Fuse present only for 100-240 Vac models.
Every fuse replacement must be performed with a power off device using a TR5 630 mA 250 V fuse.

ELECTRICAL CONNECTIONS – as per NFC15-100 standard



This connection must be made by a formed and qualified technician. To make the connection, the transmitter must not be energized. Before making the connection, you must first check the power supply indicated on the transmitter board (see (b) on "Connections" part). The presence of a switch and a circuit breaker upstream the device is compulsory

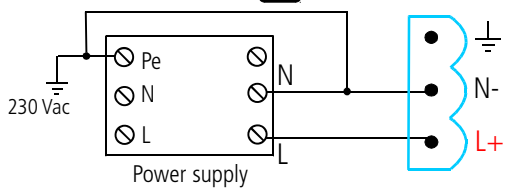
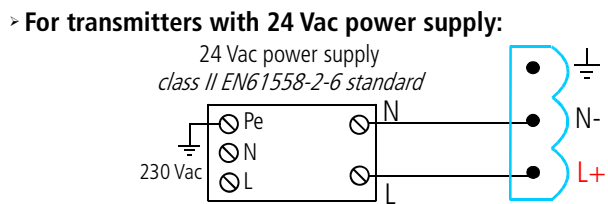
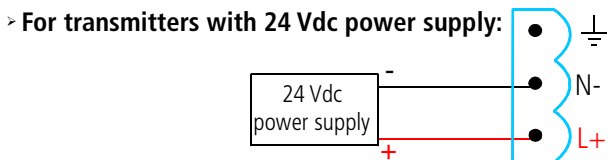

> For transmitters with 100-240 Vac power supply:

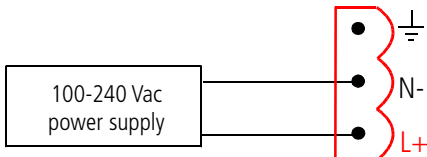

On 100-240 Vac models, if a fuse protection is used for the power line, it is imperative to use delayed-action fuses in order to absorb the surge of current when first turned on the transmitter.

The selection of the output signal in voltage (0-10 V or 0-5 V) or in current (4-20 mA or 0-20 mA) is made via the DIP switch (d) of the electronic board of the transmitter: put the on-of switches as shown in the table below:

Configurations	4-20 mA	0-10 V	0-5 V	0-20 mA
Combinations				
	1 2 3 4	1 2 3 4	1 2 3 4	1 2 3 4

> Connection of the output in current 4-20 mA:

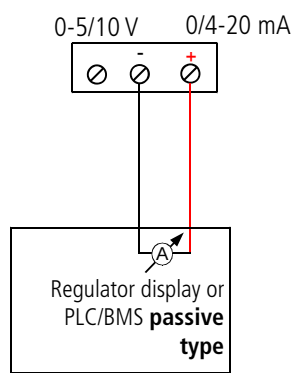

4-20 mA output

> Connection of output in voltage 0-10 V:

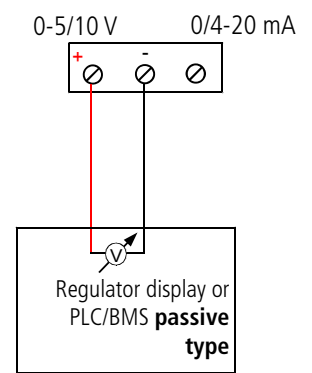

0-10 V output

CONFIGURATION OF THE TRANSMITTERS

It is possible on the class 210 to configure all the parameters of the transmitter: units, measuring ranges, outputs, channels, calculation functions, etc. via different methods:

- **Keypad** for models with display: a code-locking system allows to secure the installation (See class 210 transmitters user manual).
- **Software** (optional) on all models. Simple user-friendly configuration. See LCC-S user manual.

Configurable analogue output:

Range with center zero (-40/0/+40°C), with offset zero (-30/0/+70°C) or standard range (0/+100°C).

It is possible to configure your own intermediary ranges

Caution: the minimum difference between the high range and the low range is 20.

Configure the range according to your needs: outputs are automatically adjusted to the new measuring range

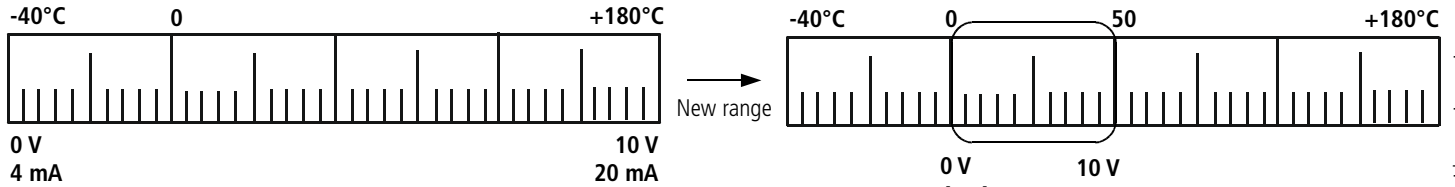

MOUNTING

To mount the transmitter, mount the ABS plate on the wall (drilling: $\varnothing 6$ mm, screws and pins are supplied).

Insert the transmitter on the fixing plate (see A on the drawing beside). Rotate the housing in clockwise direction until you hear a "click" which confirms that the transmitter is correctly installed.

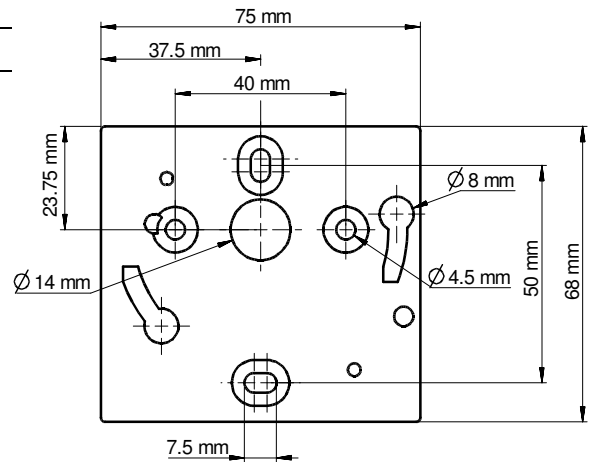

CALIBRATION

Outputs diagnostic: With this function, you can check with a multimeter (or on a regulator / display, or a PLC / BMS) if the transmitter outputs work properly. The transmitter generates a voltage of 0 V, 5 V and 10 V or a current of 4 mA, 12 mA and 20 mA

Certificate: Class 210 transmitters are supplied with adjusting certificates. Calibration certificates are available as an option.

MAINTENANCE

Please avoid any aggressive solvent. Please protect the transmitter and its probes from any cleaning product containing formalin, that may be used for cleaning rooms or ducts.

OPTIONS AND ACCESSORIES

- **LCC-S:** configuration software with USB cable
- **Calibration certificate**
- Sliding fittings
- Connection fittings
- Cable glands
- Protections tips
- Wall-mounting support bracket for remote humidity probe

 Only the accessories supplied with the device must be used.

PRECAUTIONS FOR USE

Please always use the device in accordance with its intended use and within parameters described in the technical features in order not to compromise the protection ensured by the device.



Once returned to KIMO, required waste collection will be assured in the respect of the environment in accordance with European guidelines relating to WEEE.

大華高科股份有限公司

www.taiwah.com.tw info@taiwah.com.tw

台北 TEL: (02) 2592 - 5119 Fax: (02) 2592- 3577

台中 TEL: (04) 2707 - 2269 Fax: (04) 2707- 1799

台南 TEL: (06) 243 - 2338 Fax: (06) 243 - 2339

KIMO® 為 KIMO 儀器公司的註冊商標。

資料中任何商標和圖片為本公司版權所有。未經本公司書面許可不得以任何形式複製、轉印、發行或儲存資料中所包含的訊息。本資料如有變更，恕不另行通知。